

南方安华

**NOWFOREVER**

**B3000 Series Inverter**  
**User manual**  
**V1.4**

# Contents

<b>1. Preface</b> .....	<b>4</b>
<b>2. Inspection</b> .....	<b>5</b>
<b>3. Safety precautions</b> .....	<b>6</b>
3.1 Safety definition .....	6
3.2 Safety items .....	6
3.3 Notice Items .....	9
<b>4. Specifications and Optional Parts</b> .....	<b>12</b>
4.1 Specifications .....	12
4.2 Products Series Introduction .....	14
4.2.1 B3000 Models .....	14
4.2.2 Ordering information of B3000 series .....	15
4.2.3 Size .....	16
4.2.4 Protective cover .....	20
4.2.5 LED Keypad Display Unit Size .....	20
4.2.6 Optional Parts .....	21
4.2.7 Braking Resistor and Recommendation of Braking Unit .....	22
<b>5. Installation and wiring</b> .....	<b>25</b>
5.1 Installation .....	25
5.1.1 EMC Compliance Installation .....	26
5.1.2 Noise Suppression .....	28
5.1.3 Using Surge Suppressor .....	30
5.1.4 Leakage Current .....	30
5.1.5 Applications of Power Filter .....	31
5.1.6 AC Line Reactor Applications .....	31
5.2 Wiring .....	32
5.2.1 Overview .....	33
5.2.2 Power Terminals .....	36
5.2.3 Control Circuit Wiring .....	37
5.2.4 Onsite Wiring Requirements .....	48
5.2.5 Earthing .....	49
<b>6. Operation Procedures</b> .....	<b>51</b>
6.1 Operation Guide .....	51
6.1.1 LED Keypad .....	51
6.1.2 Keypad Function Explanation .....	52
6.1.3 Indicator Description .....	52
6.1.4 Parameter Setting Method .....	53

## Users Manual

---

6.1.5	Fault reset . . . . .	54
6.1.6	Motor parameter self-learning . . . . .	54
6.17	Password Settings . . . . .	55
6.18	Operation Mode Selection Priority . . . . .	55
6.19	The main priorities set frequency . . . . .	55
<b>7.</b>	<b>Parameters . . . . .</b>	<b>56</b>
7.1	Basic Parameters (P0) . . . . .	56
7.2	Motor Parameter (P1) . . . . .	61
7.3	Start/Brake Parameter (P2) . . . . .	64
7.4	Flux vector control parameters (P3) . . . . .	68
7.5	Current vector control parameter (P4) . . . . .	71
7.6	Multi-function terminal (P5) . . . . .	72
7.7	Output terminal control parameters (P6) . . . . .	84
7.8	Close-loop control (P7) . . . . .	90
7.9	MS parameters (P8) . . . . .	97
7.10	Enhanced function (P9) . . . . .	98
7.11	Display Control Parameters (PA) . . . . .	112
7.12	Communication (PB) . . . . .	114
7.13	Traverse Parameters (PC) . . . . .	115
7.14	PLC parameters (PD) . . . . .	119
7.15	Protection (PL) . . . . .	124
7.16	Operation Time and Temperature of Cooling Fan (PN) . . . . .	129
7.17	Protection of Parameters (PP) . . . . .	130
7.18	Factory Default (PU) . . . . .	131
<b>8.</b>	<b>Troubleshooting . . . . .</b>	<b>132</b>
<b>9.</b>	<b>Maintenance . . . . .</b>	<b>140</b>
9.1	Routine Maintenance . . . . .	140
9.2	Periodic Maintenance . . . . .	140
9.3	General Inspection: . . . . .	141
9.4	Replacing Easily-worn Parts. . . . .	141
9.5	Storing Inverters . . . . .	142
9.6	Warranty . . . . .	142
	<b>Parameter Set . . . . .</b>	<b>143</b>
<b>10.</b>	<b>Communication Protocol . . . . .</b>	<b>184</b>
10.1	Communication Mode . . . . .	184
10.2	Protocol Format . . . . .	184
10.3	Protocal function. . . . .	184
10.4	Application . . . . .	193



## **1. Preface**

Thank you for using B3000 series inverter made by Shenzhen Nowforever Electronics Technology Co., Ltd.

B3000 series satisfies high performance requirements by using a unique control method to achieve high torque, high accuracy and wide speed-adjusting range. Its anti-tripping function and capabilities of adapting severe power network, temperature, humidity, and dusty environment exceeds those of similar products made by other companies, which improves the products reliability noticeably.

B3000 consider customers' needs and combines general purpose function and industrial-oriented function. It features PI control, simple PLC, flexible I/O terminals and pulse frequency setting. You can select whether to save the parameters upon power off or stop, bind frequency setting channel with command channel, zero frequency return difference zero frequency hysteresis, main and auxiliary frequency setting, traverse operation, length control, etc. It is an integral, cost-effective and highly reliable solution for manufacture in the related fields.

B3000 series can satisfy the customers' requirements on low noise and EMI by using optimized PWM technology and EMC design.

This manual provides information on installation, wiring, parameters setting, trouble-shooting, and routine maintenance. In order to ensure the correct installation and operation of the inverter, please read this manual carefully before using and keep it in a safe place.

## **2. Inspection**

Don't install or use any inverter that is damaged or have fault parts otherwise may cause injury.

Check the following items when unpacking the inverter.

1. Ensure there is operation manual and warranty cards in the packing box.
2. Inspect the entire exterior of inverter to ensure there are no scratches or other damaged caused by transportation.
3. Check the nameplate and ensure it is what you ordered.
4. Ensure the optional parts are what you need if you have ordered any optional parts.

Please contact the local agent if there is any damage in the inverter or the optional parts.

### 3. Safety precautions

#### 3.1 Safety definition

In this manual, the safety precautions are sorted to “Danger” or “Caution”



**Operations without following instructions can cause personal injury or death.**



**Operation without following instructions can cause personal injury or damage to product or other equipment.**

#### 3.2 Safety items

**Before installation:**



1. Please don't use the inverter of being scathed or loss of parts!
2. Please use the insulating motor upwards B class; otherwise it will result in death or serious injury on account of getting an electric shock!

**When installation:**



Please install the inverter on the fireproofing material (such as metal) to prevent fire!



1. When you need to install two or more inverters in one cabinet, cooling fans should be provided to make sure that the ambient temperature is lower than 45°C. Otherwise it could cause fire or damage to the device.
2. No wires head or screws fall into the inverter!

**When wiring:**



1. Only qualified personnel shall wire the inverter!
2. Inverter and power must be comparted by the breaker; otherwise the fire will be caused!
3. Never wire the inverter unless the input AC is totally disconnected!
4. The ground terminal must be properly earthed to reduce electrical accident!

## Users Manual

---



1. Connect input terminals(R,S,T) and output terminals(U,V,W) correctly. Otherwise it will cause damage the inside part of inverter!
2. Make sure that the wiring according with EMC requirements and safety standards in the region, the wire diameter used reference the manual suggested; otherwise it will cause an accident!
3. Brake resistor cannot be directly connected between “DC bus+” and “DC bus-” terminals, or it may cause a fire!

### Before power-on:



1. Please confirm whether the power and voltage level is consistent with the rated voltage of the inverter, input and output wiring position is correct or not, and pay attention to check whether there are short-circuit in the external circuit phenomenon, ensure the line is fastened. Otherwise the inverter may cause damage!
2. Install the cover before power-on, in order to reduce the danger of electric shock!



1. Inverters do not need to do pressure test, factory products have made this test, and otherwise it may cause an accident!
2. All the external parts are connected exactly in accordance with this manual, or it may cause an accident!

### After power-on:



1. Do not open the cover after power-on, otherwise there is a risk of electric shock!
2. Do not wire and operate the inverter with wet hands, otherwise there is a risk of electric shock!
3. Do not touch inverter terminals (including the control terminals), otherwise there is a risk of electric shock!
4. At the beginning of power-on, the inverter can carry out safety testing for



## Users Manual

---

external strong electric circuit automatically, at this time, please do not touch U,V,W terminals or motor terminals, otherwise there is a risk of electric shock!



1. If you need parameter identification, please note that the risk of injuries in motor rotation, otherwise it may cause an accident!
2. Please do not arbitrarily change the parameters of inverter manufactures; otherwise it may result in equipment damage!

### Operating status:



1. When the user selects the function re-starting, please do not stay close to the mechanical equipment, otherwise it may cause personal injury!
2. Do not touch the radiator, otherwise it may cause burn!
3. Only qualified personnel shall detect the signal, otherwise it may cause personal injury or equipment damage!



1. When the inverter is running, please avoid the sundries fall into the device, otherwise it would cause equipment damage!
2. Please do not use the method of contactor on and off to control the inverter's start-stop, otherwise it would cause equipment damage!

### When maintaining:



1. Never service and maintain and maintain the inverter with electrification, otherwise it may cause injury or electric shock!
2. Ensure the inverter's "CHARGE" light turns off before the maintenance and repair of the inverter, otherwise the residual charge on the capacitor may cause personal injury!
3. Only trained personnel shall operate and maintain this equipment, otherwise it will cause personal injury or equipment damage!!

**3.3 Notice Items**

## 1. Insulation of Motors

Before using the inverter, the insulation of motors must be checked, especially, if it is used for the first time or if it has been stored for a long time. This is to reduce the risk of the inverter from being damaged by the poor insulation of the motor winding. Please use 500V insulation tester to measure the insulation resistance. It should not be less 5MΩ.

## 2. Thermal protection of the motor

If the selection of motor and rated capacity of the inverter does not match, especially when rated power of the inverter is greater than rated power of the motor, be sure to adjust the motor protection-related parameters in the inverter or pre-installed in the motor thermal relay for motor protection.

## 3. Working above power frequency

The inverter can provide 0Hz-60Hz output frequency, if the customers need to run at 50Hz or above, please consider the affordability of mechanical devices.

## 4. The vibration of mechanical devices

When the output frequency to achieve certain values of the inverter, you may encounter a mechanical resonance point of the load devices. It can be avoided by setting the parameters of the frequency jump in inverter.

## 5. Regarding motor heat and noise

Because the output voltage of the inverter is the PWM wave, it contains some harmonics wave, Therefore, there will be some increase in temperature、noise、libration in motor and Work-frequency.

## 6. Varistors for Surge Protection or Capacity Used to improve the Power Factor

Don't connect any varistors or capacitors to the output terminals of the inverter. Because the inverter's output voltage waveform is pulse wave, otherwise, it may cause tripping or damage to components.

## 7. If circuit breaker or contactor needs to be connected between the inverter and the motor, be sure to operate these circuit breakers or contactor when the inverter has no output to avoid damaging of the inverter. Otherwise it may cause damage to the inverter module.

## 8. Using outside rated voltage

## Users Manual

---

The inverter is not suitable to be used out of the specified range of operating voltage. If needed, please use suitable voltage regulation device.

### 9. Three-phase input change to Two-phase input

Don't permit of changing three-phase inverter as two-phase to be used, or it will result in failure or damage to inverter.

### 10. Protection against lightning strike

There are transient surge suppressors inside the inverter that protect it against lightning strike.

### 11. Derating due to Altitude

Derating must be considered when the inverter is installed at high altitude, greater than 1000m. This is because the cooling effect of the inverter is less effective in the thin air. For details, please contact us.

### 12. Some special usages

If the customer need to use the wiring diagram that the manual did not mention , such as the common DC bus ,please contact us.

### 13. Disposing Unwanted inverters

1) The capacitors may explode when they are burnt.

2) Poisonous gas may be generated when the plastic parts like front covers are burns.

3) Please dispose the inverter as industrial waste.

### 14. Adaptive motor

1) Standard adaptive motor for 4 grade Squirrel-cage asynchronous induction motor. If it is not above motor that may select the inverter according to rated current of motor. If you need to inverter permanent magnet synchronous motor, please ask for support.

2)The cooling fan of non-inverter motor and the rotor axis is a coaxial connection, the effect of fan cooling is poor when the speed decreases, therefore, should be retrofitted with exhaust fan or replace for the inverter motor in the motor overheat occasion.

3) The inverter has built-in standard parameters of adaptive motor, according to the actual situation ,Motor parameter identification needs to be done or personality default value in order to be compatible with the actual value, otherwise it will affect

## **Users Manual**

---

the running results and protection performance.

4) If the short-circuit occurred in the cable or the internal motor will cause the inverter alarm, and even deep-fried machine. When the motor and cable just installed, please first conduct insulation short-circuit tests, routine maintenance is also required to conduct this test regularly.

**Before using, please read this manual thoroughly to ensure proper usage. Keep this manual at an easily accessible place so that can refer anytime as necessary.**

## 4. Specifications and Optional Parts

### 4.1 Specifications

Table2-1 B3000 Specifications

Item		Description
Input	Rated voltage; Frequency	B3000-4Txxxxx: 380V~440V; 50Hz/60Hz B3000-2Sxxxxx: 200V~240V; 50Hz/60Hz
	Permissible fluctuation range	Continuous fluctuation range $\leq\pm 10\%$ , Short time fluctuation range $\leq -15\%\sim +10\%$ ; Voltage unbalance range $\leq 3\%$ ; Frequency $\leq 5\%$
Output	Rated voltage	B3000-4Txxxxx: 0~380V/440V B3000-2Sxxxxx: 0~200V/240V
	Frequency	0Hz~650Hz
	Over load ability	150%rated current for 1 minute, 180%rated current for 3s/1s(380V/220V series),200% rated current for 0.5s;
Control functions	Modulation mode	Flux vector PWM modulation
	Speed range	1: 100
	Starting torque	180% rated torque at 0.5Hz
	Accuracy of speed at steady state	$\leq\pm 0.5\%$ rated synchronous speed
	Torque boost	Auto torque boost, Manual torque boost
	Acc/Dec curve	Linear、S curve;
	Jog	Jog frequency, Acc/Dec time, Jog interval adjustable can be set
	Multi-speed operation	Seven sections of frequency. Able to achieve through the built-in PLC or terminals.
	Closed-loop control	Analog closed-loop, speed PG closed-loop control
	Auto energy saving	Automatic control excitation current, energy-saving operation.
	Auto voltage regulation	That AVR,constant output voltage even if electric network voltage fluctuates
Auto current limiting	Automatically limit the current magnitude, against overcurrent failure	
Auto carrier-wave regulation	Depending on the temperature conditions, automatically adjust the carrier frequency;	
Customize	Traverse for textile motor	Preset frequency, swing, kick frequency, period, etc. can be set up

## Users Manual

Item		Description
ed and operating functions	Set length control	When reaching set length, the inverter will stop
	Internal counter	X terminals realized by external pulse signal count
	Droop control	Current control for multiple inverters drive the same load
	Tone selection	When low carrier frequency, adjust the tone with motor running
	Instantaneous stop non-stop	When momentary power by bus voltage control, drive non-stop
	Channel binding	Command channel can bind with frequency. Setting channel and switched synchronizingly
	Methods of inputting commands	Via keypad panel、 terminals and serial port
	Methods of setting up frequency	Digital setting、 VCI、 CCI、 pulse setting、 serial port
	Auxiliary frequency	Flexible auxiliary frequency tuning、 frequency synthesis
Pulse output terminal	0~50kHz pulse signal output . Signals can be reference frequency and output frequency	
Analog output terminals	2 analog outputs of 0/4~20mA and 0~10V(selectable). Be able to output signals like reference frequency and output frequency.	
Protection function		Phase loss failure, Over/Under current, Over/Under voltage protection, Overheat and overload protection
Environment	Operating environment	In-door,
	Altitude	Less than 1000m (1000 meters above derating required)
	Ambient temperature	-10℃~+40℃ , derating is required from 40~50℃ ; Increase every 1 above 40℃, derating 2%, highest temperature allowed: 50℃
	Humidity	Less than 95% RH, no condensing
	Vibration	Less than 5.9m/s <sup>2</sup> (0.6g)
	Storage temperature	-40℃~+70℃
Enclosure	Protection level	IP20
	Cooling	Fan cooling
Mounting mode		Mounted in a cabinet

## 4.2 Products Series Introduction

### 4.2.1 B3000 Models

Table2-2 Inverter series

Inverter model (G: Constant; )	Rated capacity (kVA)	Rated input current (A)	Rated output current (A)	Moto power (kW)
B3000-2S0004G	1.0	5.4	2.5	0.4
B3000-2S0007G	1.5	8.2	4.0	0.75
B3000-2S0015G	3.0	14.0	7.5	1.5
B3000-2S0022G	4.0	23.0	10.0	2.2
B3000-2T0004G	1.0	3.2	2.5	0.4
B3000-2T0007G	1.5	6.4	4.0	0.75
B3000-2T0015G	3.0	10.0	7.5	1.5
B3000-2T0022G	4.0	12.0	10.0	2.2
B3000-2T0040G	5.9	19.0	17.0	4.0
B3000-2T0055G	8.5	28.0	25.0	5.5
B3000-2T0075G	11.0	35.0	32.0	7.5
B3000-4T0007G	1.5	3.4	2.1	0.75
B3000-4T0015G	3.0	5.0	3.7	1.5
B3000-4T0022G	4.0	5.8	5.0	2.2
B3000-4T0040G	6.3	10.0	9.0	4
B3000-4T0055G	8.5	15.5	13.0	5.5
B3000-4T0075G	11.0	20.5	17.0	7.5
B3000-4T0110G	17.0	26.0	25.0	11
B3000-4T0150G	21.0	35.0	32.0	15
B3000-4T0185G	24.0	38.5	37.0	18.5
B3000-4T0220G	30.0	46.5	45.0	22
B3000-4T0300G	40.0	62.0	60.0	30
B3000-4T0370G	50.0	76.0	75.0	37
B3000-4T0450G	60.0	92.0	90.0	45
B3000-4T0550G	72.0	113.0	110.0	55
B3000-4T0750G	100.0	157.0	152.0	75
B3000-4T0900G	116.0	180.0	176.0	90
B3000-4T1100G	138.0	214.0	210.0	110
B3000-4T1320G	167.0	256.0	253.0	132
B3000-4T1600G	200.0	307.0	304.0	160
B3000-4T1850G	230.0	355.0	350.0	185
B3000-4T2000G	250.0	385.0	380.0	200
B3000-4T2200G	280.0	430.0	426.0	220
B3000-4T2500G	309.0	488.0	470.0	250
B3000-4T2800G	342.0	525.0	520.0	280
B3000-4T3150G	388.0	605.0	590.0	315
B3000-4T3550G	427.0	667.0	650.0	355
B3000-4T4000G	454.0	701.0	690.0	400
B3000-4T4500G	510.0	789.0	775.0	450

## Users Manual

Inverter model (G: Constant; )	Rated capacity (kVA)	Rated input current (A)	Rated output current (A)	Moto power (kW)
B3000-4T5000G	566.0	877.0	860.0	500
B3000-4T5600G	625.0	982.0	950.0	560
B3000-4T6300G	724.0	1184.0	1100.0	630
B3000-4T8000G	921.0	1500.0	1400.0	800

### 注意:

B3000-4T1320G~B3000-4T2800GDC reactor is optional,  
B3000-4T3150G~B3000-4T8000GDC reactor as standard.

### 4.2.2 Ordering information of B3000 series

Please refer to Figure2-1a and Figure 2-1b.

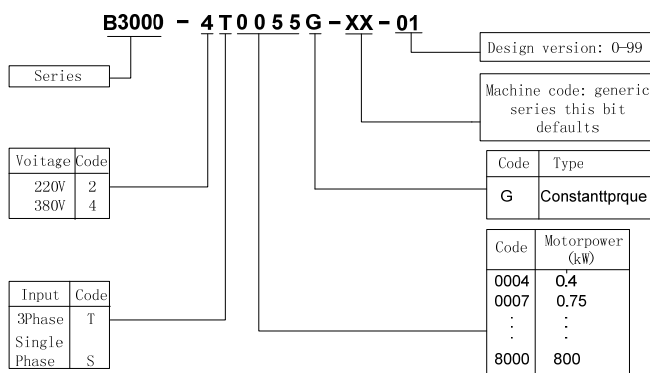

Table2-1a Explanations of inverter models

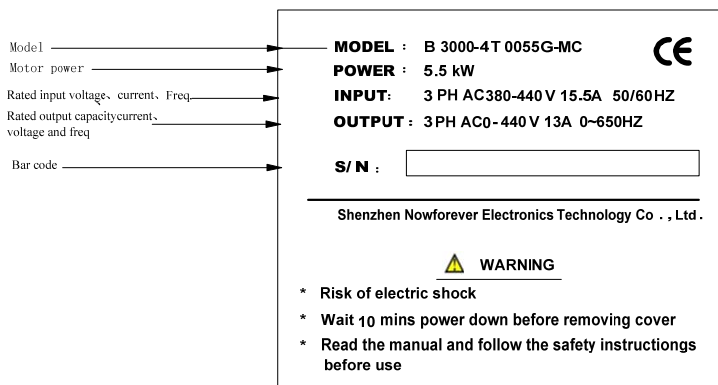

Table2-1b B3000 series nameplate



## Users Manual

## 4.2.3 Size

Please refer to Figure 2-2 and Table 2-3.

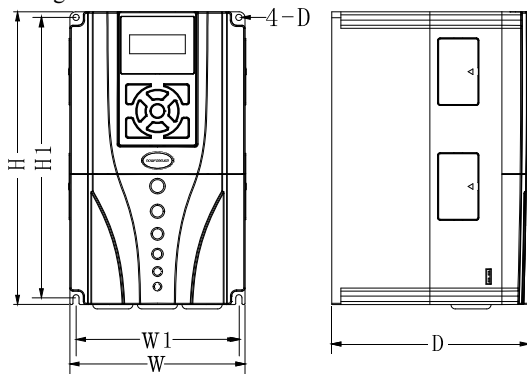

Figure a

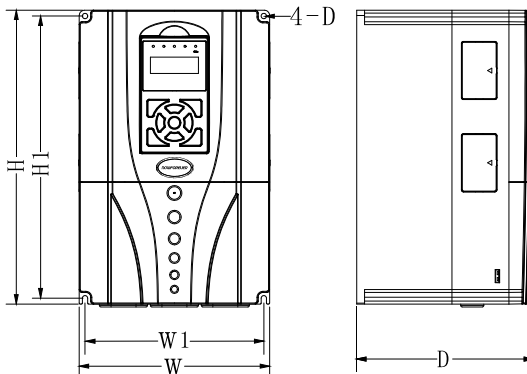

Figure b

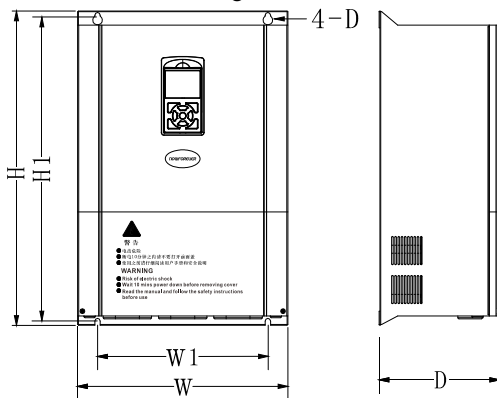

Figure c

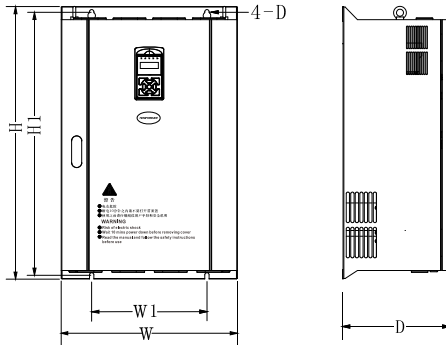

Figure d

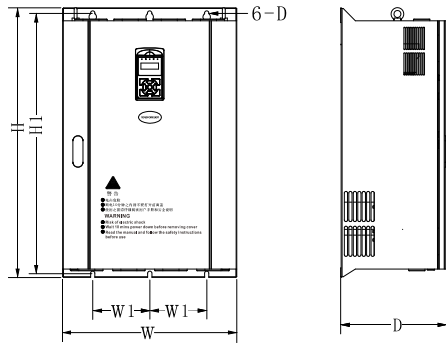

Figure e

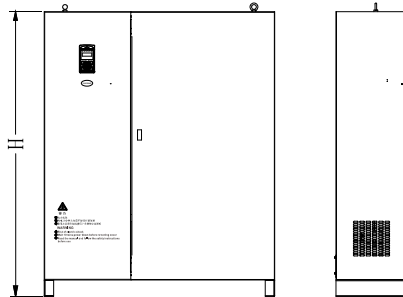
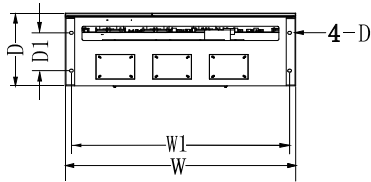

Figure g

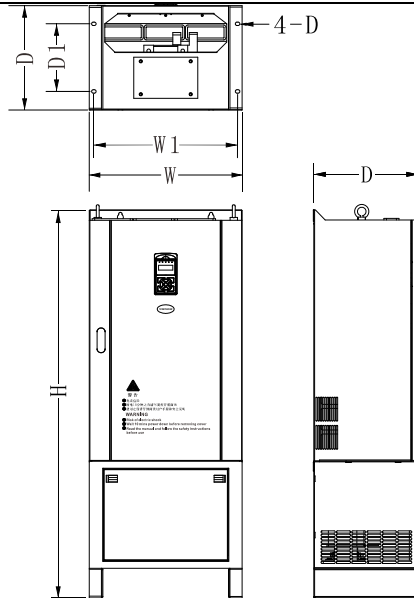

Figure f

Figure2-2 B3000 series inverter size

Table 2-3 Dimensions of B3000 series (mm)

Inverter model	D	W1	H1	H	W	Figures	Diameter of mounting hole (mm)	Gross weight (kg)	Installation
B3000-2S0004G	135	90	170	180	105	图 a	5	1.8	挂式
B3000-2S0007G									
B3000-2S0015G									
B3000-2S0022G									
B3000-4T0007G									
B3000-4T0015G									
B3000-4T0022G	175	127	200	215	140	图 a	5.5	2.5	挂式
B3000-4T0040G									

## Users Manual

Inverter model	D	W1	H1	H	W	Figures	Diameter of mounting hole (mm)	Gross weight (kg)	Installation
B3000-4T0055G	181	146	251	262	157	图 b	5.5	5	Hangi ng
B3000-4T0075G									
B3000-4T0110G	181	180	288	305	198	图 c	5.5	8	Hangi ng
B3000-4T0150G									
B3000-4T0185G	220	230	424.5	438	276	图 c	7.0	18	Hangi ng
B3000-4T0220G									
B3000-4T0300G									
B3000-4T0370G	231. 5	320	571	589	395	图 d	10.0	45	Hangi ng
B3000-4T0450G									
B3000-4T0550G									
B3000-4T0750G	298	320	733	759	489	图 d	12.0	75	Hangi ng
B3000-4T0900G									
B3000-4T1100G									
B3000-4T1320G	370	320	898	927	539	图 d	12.0	125	Comp atible hangi ng cabin et
B3000-4T1600G									
B3000-4T1850G									
B3000-4T2000G	373	507	898	1377	539	图 f	12.0	142	
B3000-4T2200G									
B3000-4T2500G									
B3000-4T2800G	373	280	1022	1054	704	图 e	12.0	160	Comp atible hangi ng cabin et
B3000-4T2500G									
B3000-4T2800G		672	1022	1500	704	图 f		181	

## Users Manual

Inverter model	D	W1	D1	H	W	Figures	Diameter of mounting hole (mm)	Gross weight (kg)	Installation
B3000-4T3150G	400	924	240	1684	960	图 f	14.0	365	Cabinet
B3000-4T3550G									
B3000-4T4000G									
B3000-4T4500G									
B3000-4T5000G									
B3000-4T5600G									
B3000-4T6300G	460	1386	240	1808	1464	图 g	18.0	*	Cabinet
B3000-4T8000G									

### 4.2.4 Protective cover

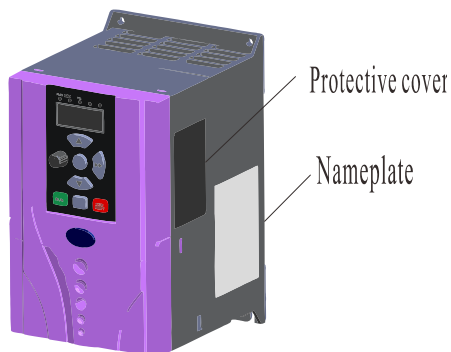

Notice: For ventilation, try not to use protective cover, unless there is a need, so that you can extend the inverter's life. B3000-4T0040G cannot use protective covers.

### 4.2.5 LED Keypad Display Unit Size

Through it, operation and configuration of the inverter can be done. Please refer to its size and configuration in Figure 2-3.

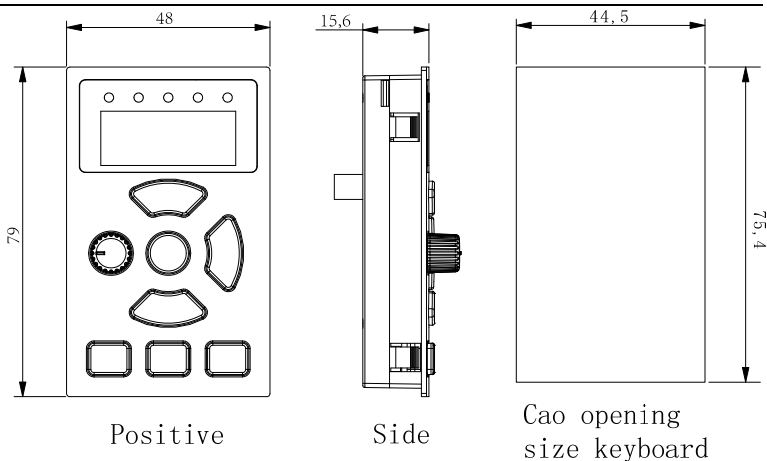

Keypad dimensions of B3000-2S0004G~4T0022G

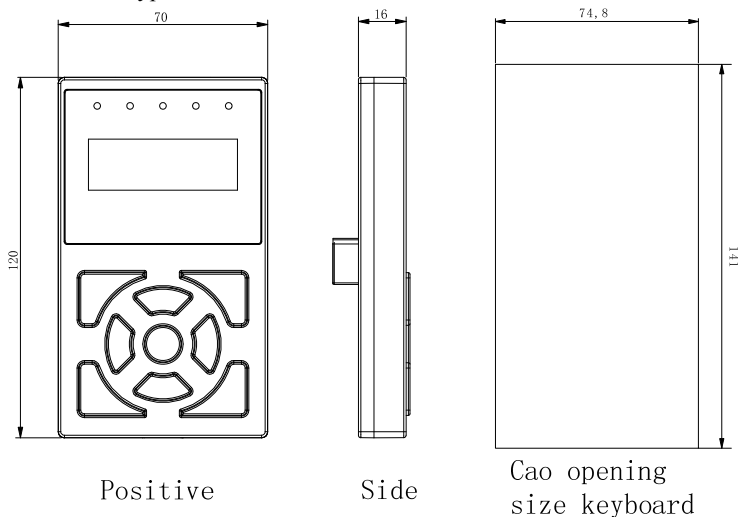

B3000-4T0040G above keyboard Dimensions

Figure2-3 Keypad Display Unit

#### 4.2.6 Optional Parts

You may order the optional parts below from our company.

Accessory Name	Selection range	Specification	Remark
Braking Unit	Table 2-4	Table 2-4	
Keyboard adapter plate	0.4KW~4.0KW optional	-	After the transfer of available network cable

## Users Manual

Accessory Name	Selection range	Specification	Remark
Keyboard Tray	4.0KW or more optional	74.7×141	Opening size
Keyboard extension cable	0.4KW~2.2KW optional	1.5m	排线
	0.4KW~800KW optional	2m、3m	网线;
Cabinet base	132KW~200KW optional	539*370*485	132KW ~ 280KW installation compatible with hanging and cabinet
	220KW~280KW optional	704*366*480	
DC reactor	132KW~280KW optional	-	-

### 4.2.7 Braking Resistor and Recommendation of Braking Unit

B3000 series inverter is equipped with braking unit. If there is a need for energy-consuming braking, please select a braking resistor in Table2-4; The wire specifications are listed in Table2-4.

Table2-4 Braking Resistor and Recommendation of Braking Unit

Model	Suggested value of resistance	Suggested power	Suggested model of braking unit	Remark
B3000-4T0007G	250-350 Ω	100W	Built-in standard parts	No special instructions
B3000-4T0015G	200-300 Ω	200W		
B3000-4T0022G	100-250 Ω	250W		
B3000-4T0040G	100-150 Ω	300W		
B3000-4T0055G	80-100 Ω	500W		
B3000-4T0075G	60-80 Ω	700W		
B3000-4T0110G	40-50 Ω	1KW		
B3000-4T0150G	30-40 Ω	1.5KW	Built-in standard parts or BU4R075	Add “B” at the end of model
B3000-4T0185G	25-30 Ω	2KW		
B3000-4T0220G	20-25 Ω	2.5KW		
B3000-4T0300G	15-20 Ω	3KW		
B3000-4T0370G	15-20 Ω	3.5KW		
B3000-4T0450G	10-15 Ω	4.5KW		
B3000-4T0550G	10-15 Ω	5.5KW	BU4R150	External optional
B3000-4T0750G	8~10 Ω	7.5 KW		
B3000-4T0900G	8~10 Ω	9.0KW		
B3000-4T1100G	6~8 Ω	11.0KW	BU4R250	External optional
B3000-4T1320G	6~8 Ω	13.5KW		
B3000-4T1600G	4~6 Ω	16.0KW		

## Users Manual

Model	Suggested value of resistance	Suggested power	Suggested model of braking unit	Remark
B3000-4T1850G	4~6 Ω	18.5 KW		
B3000-4T2000G	4~6 Ω	20.0 KW	BU4R250*2	External optional
B3000-4T2200G	6~8*2 Ω	11.0*2 KW		
B3000-4T2500G	6~8*2 Ω	12.5*2 KW		
B3000-4T2800G	4~6*2 Ω	14*2 KW		
B3000-4T3150G	4~6*2 Ω	16*2 KW		
B3000-4T3550G	4~6*3 Ω	11*3 KW	BU4R250*3	External optional
B3000-4T4000G	4~6*3 Ω	14*3 KW		
B3000-4T4500G	4~6*3 Ω	17*3 KW		
B3000-4T5000G	4~6*3 Ω	21*3 KW		
B3000-4T5600G	4~6*3 Ω	25*3 KW		
B3000-4T6300G	*	*	*	
B3000-4T8000G	*	*	*	

P.S: the calculation method of braking resistance:

When braking is enabled, almost all renewable energy have been consumed by the braking resistor, please follow the following formula:

$$U \times U / R = P_b$$

In this formula: U means the braking voltage of the system( The value of U may differ from each system, I.e, 380Vac system, U is 700V generally.

$P_b$  is the braking power

Power selection for braking resistor

Theoretically, the braking resistor's power is the same as the braking power, however by taking the 70% derate into consideration, you can use the following formula to calculate the braking resistor's power:

$$0.7 \times P_r = P_b \times D$$

$P_r$ --power of the braking resistor

D--braking frequency

Braking frequency values for standard elevator and winder applications:

Applications	Elevator	Winding and unwinding	Centrifuge machine	Occasionally braking load	General applications
Braking frequency(D)	20% ~30%	20 ~30%	50%~60%	5%	10%

The above Table 2-4 is a guide reference only, users can choose different braking resistance and power according to each application. However, please be remembered that the braking resistance shouldn't be less than the above recommended value, but the power is allowed to be exceed than the recommend numbers. Users need to select the right braking resistors according to each application case, there are quite a few aspects which will determine your choice of the resistors, such as the power of the



## **Users Manual**

---

motor, system inertia, deceleration time, the energy of the load etc. The greater the system inertia is, the shorter the required deceleration time is required, then the braking frequency will be increased, which means you need to choose a bigger power braking resistor with a lower braking resistance.

## 5. Installation and wiring

### 5.1 Installation

Please mount the inverter vertically indoors, with good ventilative conditions.

When selecting mounting environment, the followings should be taken into account:

Ambient temperature should be within the range of  $-10\text{ }^{\circ}\text{C} \sim 40\text{ }^{\circ}\text{C}$ . If the temperature is higher than  $40\text{ }^{\circ}\text{C}$ , the inverter should be derated and forced heat dissipation is required.

Humidity should be lower than 95%, non-condensing;

Mount in the location where vibration is less than  $5.9\text{m/s}^2$  (0.6g);

Mount in the location free of direct sunlight, dust, metal powder, corrosive gas or combustible gas;

If there are any special requirements for installation, please contact us for clarifications.

The requirements on mounting space and clearance are shown in figure 3-1 and 3-2; When two inverters are mounted one on top the other, an air flow diverting plate should be fixed in between as shown in figure 3-3.

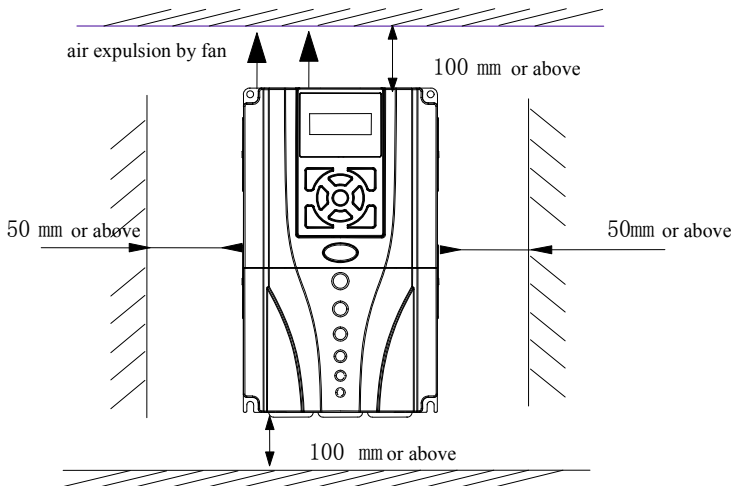

Figure 3-1 Installation clearance

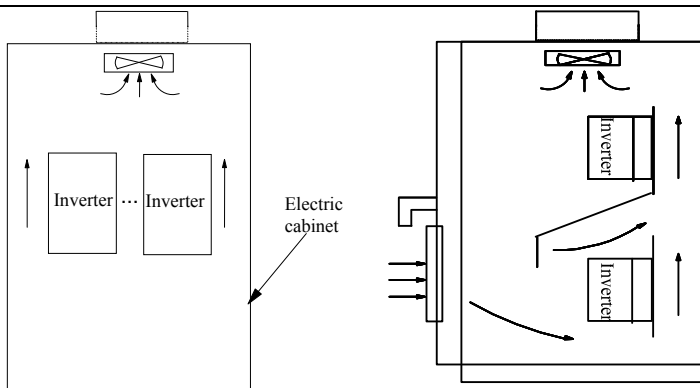

Figure3-2 Installation of several inverters      Figure3-3 Installation of one on top the other

### 5.1.1 EMC Compliance Installation

In a traction system composed of a inverter and a motor, if the inverter, controllers and transducer are installed in one cabinet, the disturbance they generate should be depressed at the connection points, therefore, a noise filter and inrush reactor should be installed in the cabinet, so that EMC requirement is met inside it.

The inverter is usually installed in a metal cabinet, the instruments outside the metal cabinet is shielded and may be disturbed lightly. The cables are the main EMI source, if you connect the cables in according to the manual, the EMI can be suppressed effectively.

In system design phase, to reduce EMI, insulating the noise source and use the noise subber are the best choice, but the choice is considerable. If there are a few sensitive devices on site, just install the power line filter beside them is enough note that the inverter and the contactor are noise source, and the automatic devices encoder and conductor are sensible to them.。

Divide the system into several EMC parts; refer to figure 3-4.

#### Note:

- 1 . After installing EMI filter and AC reactor, the inverter can satisfy IEC 61800—3 standard.
- 2 . The input/output filter should be installed close to the inverter as possible.

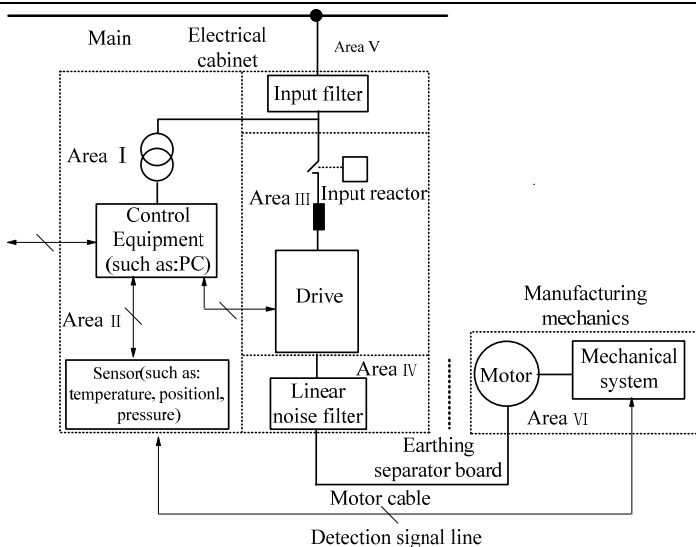

Figure3-4 Recommended System Layout:

Area I : Should be used to install transformers for control power supply, control system and sensor.

Area II : Should be used for interface of signal and control cables with good immunity level.

AreaIII: Should be used to install noise generating devices such as input reactor, inverter, brake unit and contactor.

AreaIV: Should be used to install output noise filter.

Area V : should be used to install power source and cables connecting the RFI filter.

AreaVI: should be used to install the motor and motor cables.

Areas should be isolated in space, so that electro-magnetic decoupling effect can be achieved. The shortest distance between areas should be 20cm.

Earthing bars should be used for decoupling among areas; the cables from different area should be placed in different tubes.

The filter should be installed at the interfaces between different areas if necessary. Bus cable (such as RS485) and signal cable must be shielded.

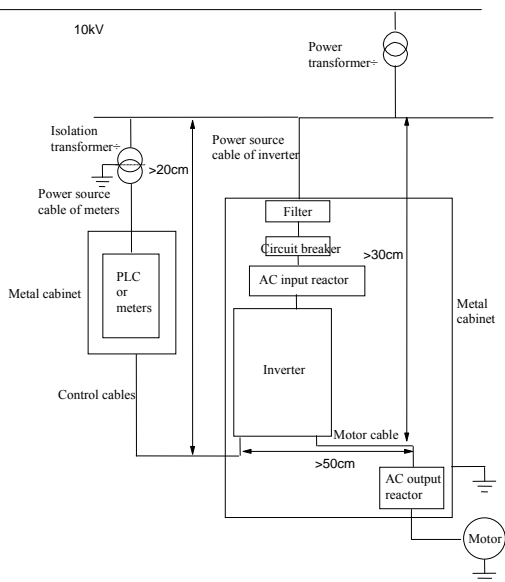

Figure 3-5 Installation of the inverter

### 5.1.2 Noise Suppression

The noise generated by the inverter may disturb the equipment nearby; the degree of disturbance is depend on the inverter system, immunity of the equipment, wire connections, installation clearance and earthing methods.

Table3-1 Actions to reduce the noise

Noise emission paths	Actions to reduce the noise
<p>If the external equipment shares the same AC supply with the inverter, the inverter's noise may be transmitted along its input power supply cables, which may cause nuisance tripping to other external equipment .</p>	<p>Install noise filter at the input side of the inverter, and use an isolation transformer or line filter to prevent the noise from disturbing the external equipment</p>
<p>If the signal cables of measuring meters, radio equipment and sensors are installed in a cabinet together with the inverter, these equipment cables will be easily disturbed.</p>	<p>1) The equipment and the signal cables should be as far away as possible from the inverter. The signal cables should be shielded and the shielding layer should be grounded. The signal cables should be placed inside a metal tube and should be located as far away as possible from the input/output cables of the inverter. If the signal cables must cross over the power cables, they should be placed at right angle to one another.  2) Install radio noise filter and linear noise filter (ferrite common-mode choke) at the input and output sides of the inverter to suppress the emission noise of power lines.  3) Motor cables should be placed in a tube thicker than 2mm or buried in a cement conduit. Power cables should be placed inside a metal tube and be grounded by shielding layer (Motor cable should be a 4-core cable, where one core should be connected to the PE of the inverter and another should be connected to the motor's enclosure)</p>
<p>If the signal cables are routed in parallel with the power cables or bundle these cables together, the induced electro-magnetic noise and induced ESD noise may disturb the signal cables.</p>	<p>Avoid this kind of routing. Other equipment sensible to EMI should also be located as far away as possible from the inverter. The signal cables should be placed inside a metal tube and should be placed as far away as possible from the input/output cables of the inverter. The signal cables and power cables should be shielded cables. EMC interference will be further reduced if they could be placed inside metal tubes. The clearance between the metal tubes should be at least 20cm.</p>

### 5.1.3 Using Surge Suppressor

The device such as relay, contactor and electro-magnetic braking kit, which may generate great noises, should be installed with surge suppressor even if installed outside of the device cabinet.

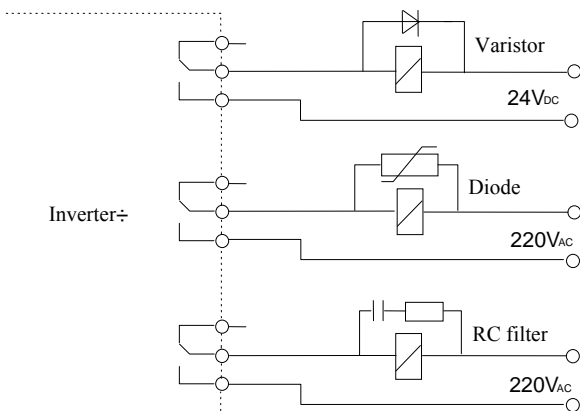

Figure3-6 Installation of Relay, contactor and electro-magnetic braking kit

### 5.1.4 Leakage Current

Leakage current may flow through the inverter's input and output capacitors and the motor's capacitor. The leakage current value is dependent on the distributed capacitance and carrier wave frequency. The leakage current includes ground leakage current and the leakage current between lines .

#### Ground leakage current

The ground leakage current not only flows into the inverter's system, but also into other equipment via earthing cables. It may cause leakage current circuit breaker and relays to be falsely activated. The higher the inverter's carrier wave frequency, the higher the leakage current, and also, the longer the motor's cable, the greater is the leakage current.

#### Suppressing methods:

Reduce the carrier wave frequency, but the motor noise may be higher;

Motor cables should be as short as possible;

The inverter and other equipment should use leakage current circuit breaker designed for protecting the products against high-order harmonic/surge leakage current .

#### Leakage current between lines

The line leakage current flowing outside though the distributed capacitor of the inverter may false trigger the thermal relay, especially for the inverter of which power rating is less than 7.5KW. If the cable is longer than 50m, the

ratio of leakage current to motor rated current may increase to a level that can cause external thermal relay to trigger unexpectedly.

Suppression methods:

Reduce the carrier wave frequency, but the motor audible noise is higher;

Install reactor at the output side of the inverter.

In order to protect the motor reliably, it is recommended to use a temperature sensor to detect the motor's temperature, and use the inverter's over-load protection device (electronic thermal relay) instead of an external thermal relay.

### **5.1.5 Applications of Power Filter**

Power source filter should be used in the equipment that may generate strong EMI or the equipment that is sensitive to EMI. The power source filter should be a low pass filter through which only 50Hz current can flow and high frequency current is rejected.

The power filter ensures the equipment can satisfy the conducting emission and conducting sensitivity in EMC standard. It can also suppress the radiated emission of the equipment

It can prevent the EMI generated by the equipment from entering power cable, and also prevent the EMI generated by the power cable from entering the equipment.

Common mistakes in using power line filter

Power cable is too long

The filter inside the cabinet should be located near to the input power source. The length of the cables should be as short as possible.

The input and output cables of the AC supply filter are too close

The distance between input and output cables of the filter should be as far apart as possible, otherwise the high frequency noise may be coupled between the cables and bypass the filter. Thus, the filtering effect becomes ineffective.

Bad earthing of filter.

The filter enclosure must be connected properly to the metal casing of the inverter. In order to be earthed well, a special earthing terminal on the filter's enclosure should be used. If you use one cable to connect the filter to the case, the earthing is useless due to high frequency interference. When the frequency is high, so too is the impedance of cable, hence there is little bypass effect.

The filter should be mounted in the enclosure of equipment. Ensure to clear away the insulation paint between the filter case and the enclosure for good earth contact.

### **5.1.6 AC Line Reactor Applications**

**Input AC Line Reactor:**



## Users Manual

A line reactor should be used if the distortion of power network is severe or the input current harmonic level is high even after a DC reactor has been connected to the inverter. It can also be used to improve the AC input power factor of the inverter.

### Output AC Line Reactor:

When the cables from the inverter to motor are longer than 80m, multi-strand cables and an AC line reactor should be used to suppress the high frequency harmonics. Thus, the motor insulation is protected. At the same time, leakage current and unexpected trigger are reduced.

## 5.2 Wiring



- Wiring can only be done after the Variable Speed Inverter's AC power is disconnected; all the LEDs on the operation panel are off and after waiting for at least 10 minutes. Then, you can remove the panel.
- Wiring job can only be done after confirming the Charge indicator inside the inverter has extinguished and the voltage between main circuit power terminals + and - is below DC36V.
- Wire connections can only be done by trained and authorize personnel.
- For the sake of safety, the inverter and motor must be earthed because there is leakage current inside the inverter; Check the wiring carefully before connecting emergency stopping or safety circuits。
- Check the Variable Speed Inverter's voltage level before supplying power to it; otherwise human injuring or equipment damage may happen.



- Check whether the inverter's rated input voltage is in compliant with the AC supply voltage before using.
- Dielectric strength test of the inverter has been done in factory and the user needs not do it again
- Refer to chapter 2 on how to connect braking resistor or braking。
- It is prohibited to connect the AC supply cables to the inverter's terminals U, V and W.
- Grounding cables should be copper cables with cross-sectional area bigger than 2.5 mm<sup>2</sup>, and the grounding resistance should be less than 10Ω.
- For the sake of safety, the inverter and motor must be earthed because there is leakage current inside the inverter。



- The control circuits of B3000 are isolated from the power circuits in the inverter by basic insulation (single insulation) only. If the control cables are to connect to external control circuit exposing to human contact, an extra insulating layer, rated for use at the AC supply voltage of the load, must be applied.
- If the control circuits are to connect to other circuits classified as Safety Extra Low Voltage (SELV), e.g. connecting the RS485 port of the inverter to a

personal computer through an adapter, an additional isolating barrier must be included in order to maintain the SELV classification.



·The control terminals of the inverter are of ELV (Extra Low Voltage) circuit. Do not touch them once energized;  
 ·If the external device has touchable terminals of SELV (Safety Extra Low Voltage) circuit. Remember to connect isolating protections in between. Otherwise, the SELV circuit will be degraded to ELV circuit;;  
 ·When connecting the inverter with PC, do choose RS485/232adapterswith isolating protections that measure up to safety requirements. .

### 5.2.1 Overview

You should finish the power circuit and control circuit wiring.

First, open the front door, and then you will see the power terminals and control terminals

For different models of the inverter, the power terminals layout is different, which is described in details as below.

(Jumpers: CN is for inverters 4.0KW and below, SW is for inverters 5.5kw~800kw)

Beneath the keypad display unit, there are control terminal strip and jumpers CN4(SW2), CN5(SW3), CN7(SW1), CN14(SW4).

Terminal strip is relay output, analog, digital I/O and communication interfaces. CN4(SW2), CN5(SW3) and CN7(SW1) are jumpers through which the output of voltage or current signal is set, the terminals will be described in details later.

The figure below is the systematic wiring of the inverter

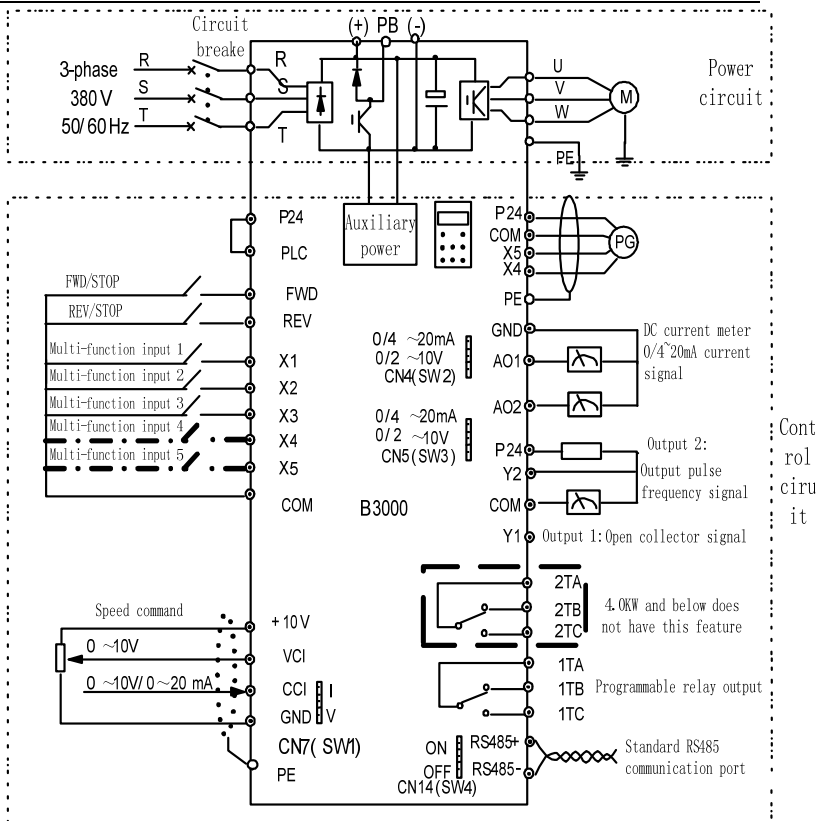

Figure 3-7 Systematic Wiring Diagram

**Note:**

- 1 . In the above figure, “O” is the terminal in power circuit, and “⊙” is the control terminal ;
- 2 . Terminal CCI can input voltage or current signal by switching the jumper CN10 on control board ;
- 3 . Built-in braking kit is installed and a braking resistor is required to be connected between P (+) and PB ;
- 4 . Refer to section 3.2.3 for the using of control terminals;
- 5 . MCCB must be installed at the input side of each inverter in the cabinet;
- 6 . Refer the cable section area and MCCB capacity to Table 3-2.

## Users Manual

Table 3-2 Recommended MCCB Capacity and Copper Cable Section Area

Model	MCCB Circuit breaker (A)	Power circuit (mm <sup>2</sup> )				Control cable (mm <sup>2</sup> )
		Input cable	Braki ng line	Output t cable	Earth cable	
B3000-2S0004G	16	1.5	1.0	1.0	2.5	1.0
B3000-2S0007G	20	2.5	1.0	1.0	2.5	1.0
B3000-2S0015G	32	4.0	1.5	2.5	4.0	1.0
B3000-2S0022G	50	6.0	1.5	2.5	6.0	1.0
B3000-4T0007G	10	1.0	1.0	1.0	2.5	1.0
B3000-4T0015G	16	1.5	1.0	1.5	2.5	1.0
B3000-4T0022G	16	1.5	1.5	1.5	2.5	1.0
B3000-4T0040G	25	2.5	1.5	2.5	2.5	1.0
B3000-4T0055G	32	4.0	2.5	4.0	4.0	1.0
B3000-4T0075G	32	4.0	2.5	4.0	4.0	1.0
B3000-4T0110G	40	6.0	4.0	6.0	6.0	1.0
B3000-4T0150G	63	6.0	4.0	6.0	6.0	1.0
B3000-4T0185G	63	10	10	10	10	1.0
B3000-4T0220G	80	16	16	16	16	1.0
B3000-4T0300G	100	25	25	25	16	1.0
B3000-4T0370G	160	25	10	25	16	1.0
B3000-4T0450G	200	35	16	35	16	1.0
B3000-4T0550G	200	35	25	35	25	1.0
B3000-4T0750G	250	70		70	35	1.0
B3000-4T0900G	310	70		70	35	1.0
B3000-4T1100G	400	95		95	50	1.0
B3000-4T1320G	400	150		150	75	1.0
B3000-4T1600G	500	185		185	95	1.0
B3000-4T1850G	600	150*2		150*2	150	1.0
B3000-4T2000G	600	150*2	Reference manual circuit breaker unit	150*2	150	1.0
B3000-4T2200G	600	150*2		150*2	150	1.0
B3000-4T2500G	800	185*2		185*2	185	1.0
B3000-4T2800G	800	185*2		185*2	185	1.0
B3000-4T3150G	800	150*3		150*3	125*2	1.0
B3000-4T3550G	800	150*4		150*4	150*2	1.0
B3000-4T4000G	1000	150*4		150*4	150*2	1.0
B3000-4T4500G	1200	180*4		180*4	180*2	1.0
B3000-4T5000G	1200	180*4		180*4	180*2	1.0
B3000-4T5600G	1500	180*4		180*4	180*2	1.0
B3000-4T6300G	2000	180*5		180*5	180*3	1.0
B3000-4T8000G	2500	180*5		180*5	180*3	1.0

**Note:**

If the control circuit uses multi-strand cable, the single-core cable section area can be  $0.5\text{mm}^2$ .

**5.2.2 Power Terminals**

1. B3000-4T0007G ~ B3000-4T0040G figure each terminal meaning the table below :

	R	S	T	(+)	(-)	PB	U	V	W
---	---	---	---	-----	-----	----	---	---	---

B3000-2S0004G ~ B3000-2S0040G figure meaning of each terminal as follows:

	L		N	(+)	(-)	PB	U	V	W
---	---	--	---	-----	-----	----	---	---	---



Table 3-4 Definitions of power terminals

Mark	Definition
R、S、T	3-phase AC input
(+)、PB	External braking resistor
(+)、(-)	DC positive, negative bus input
U、V、W	3-phase AC outputs
PE	Protective earth

2. B3000-4T0055G~B3000-4T0150G figure meaning of each terminal as follows:

R	S	T	P1	(+)	PB	(-)	U	V	W
---	---	---	----	-----	----	-----	---	---	---

	
---	---

3. B3000-4T0185G~ B3000-4T0550G figure meaning of each terminal as follows:

R	S	T	P1	(+)	PB	(-)	U	V	W	PE
---	---	---	----	-----	----	-----	---	---	---	----

Table 3-5 Definitions of power terminals

Mark	Definition
R、S、T	3-phase AC input
P1、(+)	External DC reactor reserved terminals (connect with steel before use)
(+)、PB	External braking resistor
(-)	DC negative bus input
U、V、W	3-phase AC outputs
PE	Protective earth

4. B3000-4T0750G figure above each terminal meanings as follows:

进线端子(机器顶部)

PE	R	S	T
----	---	---	---

出线端子(机器底部)

PE	U	V	W	P1	(+)	(-)
----	---	---	---	----	-----	-----

表 3-6 Definitions of power terminals

Mark	Definition
R、S、T	3-phase AC input
P1、 (+)	External DC reactor reserved terminals (315KW or more standard reactor)
(+)、 (-)	External braking resistor; External braking unit DC output terminal
U、V、W	3-phase AC outputs
$\frac{\perp}{\equiv}$ 、PE	Protective earth

### 5.2.3 Control Circuit Wiring

#### Control Terminals and Jumpers

Refer the layout to Figure 3-8. Control terminals functions are listed in Table 3-6, Jumper's functions in 3-7. Be sure to set the jumper and wire the terminals properly. It is recommended to use cable of section area bigger than 1mm<sup>2</sup>.

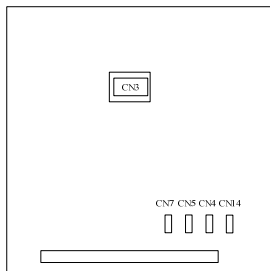

B3000-2S0004G~B3000-4T0040G

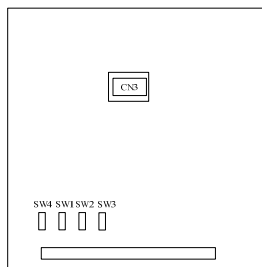

B3000-4T0055G above

Figure 3-8 Layouts of control terminals and jumpers

Table 3-6 Function of control terminals

Mark	Function
CN6- CN11	Analog I/O, digital I/O, relay outputs

Table 3-7 Jumpers' function

Mark	Function&Setting	Default
CN7 (SW1)	CCI current/voltage input selection I: 0~20mA current signal V: 0~10V voltage signal	0~10V
CN14 (SW4)	485 terminal resistor selection: ON: 120Ω terminal resistor, OFF: No terminal resistor.	No resistor
CN4 (SW2)	AO1 current/voltage input selection 0/4~20mA: AO1 current signal 0/2~10V: AO1 voltage signal	0~10V
CN5 (SW3)	AO2 current/voltage input selection 0/4~20mA: AO2 current signal 0/2~10V: AO2 voltage signal	0~10V

### Jumper usage

CN4(SW2)、CN7(SW1) or CN5(SW3) jumper usage:

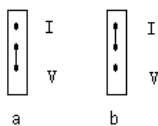

Figure a means that 0~10V analog voltage input is selected; Figure b means that 0/4~20mA analog current input is selected.

CN14(SW4) jumper usage:

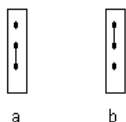

Figure a means that there is no resistor (OFF); Figure b means that there is a resistor (ON) .

### Terminal strip layout

The layout is shown below

B3000-42S0004G~B3000-4T0040G terminal strip layout:

## Users Manual

TC	TB	TA	Y1	Y2	FWD	REV	AO1	AO2	VCI	CCI	GND	
COM	PLC	P24	X1	X2	X3	X4	X5	+10V	GND	485+	485-	

B3000-4T0055G above terminal arrangement:

485+	485-	GND	AO1	AO2	X1	X2	X3	X4	X5	COM	1TA	1TB	1TC
+10V	VCI	CCI	GND	P24	PLC	COM	FWD	REV	Y1	Y2	2TA	2TB	2TC

TA-TB: Normally closed; TA-TC: Normally open

Contact capacity: 250Vac/2A (COSφ=1), 250Vac/1A (COSφ=0.4), 30Vdc /1A

TA, TB and TC can be defined as multi-functional digital output signals.

Please refer to Section 5.7

Relay output TA、TB、TC Wiring:

If there are inductive loads, such as: electro-magnetic relay and contactor, surge snubber circuit, e.g. RC circuit, varistor, fly-wheel diode (pay attention to the polarity when used in a DC circuit), should be installed. Note that the leakage current should be less than the current in the contactor or relay. The components in the snubber circuit should be installed near to the relay or contactor coil.

### Note :

The “+RS485-” in the above figure means RS485+ and RS485-.

Table 3-8 Terminal function table

Category	Terminals	Name	Function	Specification
Communication	485+	RS485 communication port	RS485+	Standard RS-485 communication port, please use twisted-pair cable or shielded cable
	485-		RS485-	
Analog input	VCI	Analog input VCI	Analog voltage input (reference ground: GND)	Input voltage range:0~10V (input resistance:100kΩ) resolution:1/2000
	CCI	Analog input CCI	Accepting analog voltage/current input.CN7(SW1) can select voltage or current input mode, Voltage input mode is the default (Reference ground: GND)	Input voltage range:0~10V (input resistance:100kΩ) Input current range:0~20mA (input resistance:500Ω) resolution:1/2000



## Users Manual

Category	Terminals	Name	Function	Specification
Analog output	AO1	Analog output 1	Be able to output analog voltage/current, (total 12 kinds of signal). Jumper CN4(SW2) can select voltage or current input mode. Voltage input mode is the default mode. Refer to P6.04 for details (reference ground: GND)	Output current range: 0/4~20mA Output voltage range: 0/2~10V
	AO2	Analog output 2	Be able to output analog voltage/current (total 12 kinds of signals). Jumper CN5(SW3) can select voltage or current input mode, Voltage input mode is the default mode. Refer to F6.05 for details.(reference ground: GND)	
Digital input	X1~X3	Multi-functional digital inputs 1~3	Can be defined as multi-functional digital inputs, see Section 5.7 Reference ground: COM	Optical-isolator 2-way input input resistance: 2kΩ maximum input frequency: 200Hz Input voltage range: 9~30V
	X4~X5	Multi-functional digital inputs 4~5	Having the same function as X1~X3, besides, it can be defined as high-speed pulse inputs. See Section 5.7. Reference ground: COM	Optical-isolator 2-way input Single way max. input frequency: 100kHz, 2-way max. input frequency: 50kHz Max. reference pulse frequency: 50Hz Input voltage range: 9~30V Input impedance: 2Ω
	FWD	Run forward command	Optical-isolator two-way input programmable terminal, max. input frequency: 200Hz	
	REV	Reverse run command	Optical-isolator two-way input programmable terminal, max. input frequency: 200Hz	
	PLC	Common terminal	Common terminal for multi-functional inputs	

## Users Manual

Category	Terminals	Name	Function	Specification
	P24	+24V supply	Providing +24V power supply	Output: +24V, set point accuracy: $\pm 10\%$ Max output current: 200mA (150mA for 2S0007G and 2S0004G)
	COM	+24V common terminal	Isolated internally with GND	Isolated internally with GND
Digital input	Y1	Open collector output 1	Programmable terminals, defined as multi-function digital outputs, see Section 5.7.	Optical-isolator output: 24Vdc/50mA
Digital output	Y2	Open collector output 2	Programmable terminals, defined as multi-function digital outputs, see Section 5.7.	Optical-isolator output: 24Vdc/50mA, Y2 can be used as digital output, Max output frequency :50kHz
Power supply	+10V	+10V power supply	Provide +10V power supply	Output: +10V, Setpoint accuracy: $\pm 10\%$ Max. output current: 100mA
	GND	GND of +10V power supply	reference ground of analog signal and 10V power supply	Isolated internally with COM
Others	1TA/1TB/ 1TC/2TA/ 2TB/2TC (B3000-4T0040G 以下的只有一组继电器)	Relay output	TA, TB and TC can be defined as multi-functional digital output signals. Please refer to Section 5.87	TA-TB: normally closed; TA-TC: normally open Contact capacity: 250Vac/2A (COS $\phi$ =1) , 250Vac/1A (COS $\phi$ =0.4) , 30Vdc /1A

## 1) Analog Input Terminal Wiring

① Terminal VCI receives analog voltage input, the wiring is as follows:

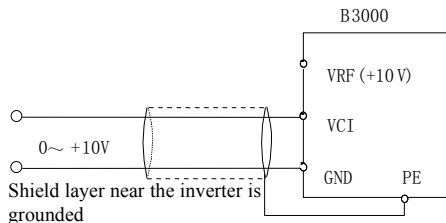

Figure 3-9 VCI Wiring Diagram

② Terminal CCI receives analog signal. Select current or voltage signal by setting jumper. Refer to the figure below:

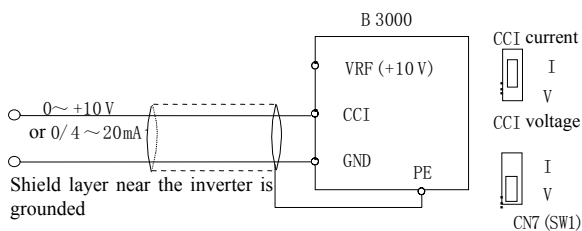

Figure 3-10 CCI Wiring Diagram

## 2) Analog Output Terminal Wiring

If the analog output terminal AO1 and AO2 are connected with analog meter, it can measure many parameters. The jumpers for AO1 and AO2 are CN4 (SW2) and CN5 (SW3).

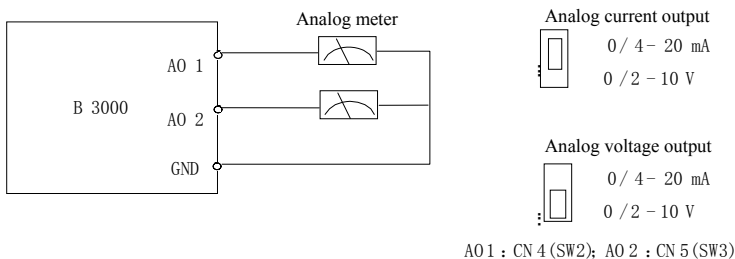

Figure3-11 Analog Output Terminal Wiring

### Note:

1 . When using analog input, you should install capacitor-filter or common-mode inductor between VCI and GND, or between CCI and GND.

2 . Analog I/O signals are sensible to interference, ensure to use shielded cable and ground it properly. The cable length should be as short as possible.

### 3) Serial Communication Port Connection

The inverter can be connected to the host with RS485 port directly.

Figure 3-12 shows the connection of the inverter with the host with RS232 port.

Using above wiring method, you can built a “single-master single-slave” system or a “single-master multi-slaves” system. The inverter in the network can be monitored, can be controlled remotely automatically in real time by using a PC or PLC controller. Thus more complicated operation control can be realized.

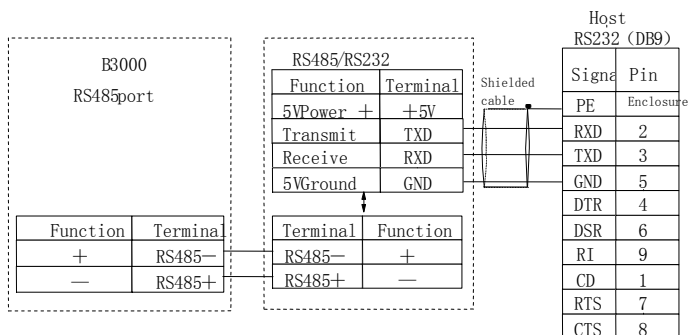

Figure3-12 RS485- (RS485/RS232) -RS232 communication cable

Precautions for communication port connection:

The PE terminal of each inverter should be earthed at a nearby grounding point;

The GND terminal of each inverter should be connected together;

RS485 communication uses shielded cables, which is earthed at one side. The earth wire of the shielded cable is connected to RS485 communication module (PE).

If the above standard wiring methods cannot meet the requirements, you can take the actions below:

Use isolated RS485 communication module;

If the noise is transmitted through the GND line to the inverter or other devices, which results in malfunction of them, you may disconnect the GND lines.

### 4) Multi-function Input Terminal and FWD, REV Wiring

## Users Manual

The multi-function input terminals use full-bridge rectifying circuit, as the below figure shows. PLC is the common terminal for X1~X5, FWD and REV. The PLC terminal can sink or source current. Wire connections X1~X5, FWD and REV is flexible and the typical wiring is shown below:

### ① Connection method 1

It is default to use the inverter's internal power source 24V, i.e. PLC connected with P24.

If you want to use external power supply, make sure to remove the wire between PLC and P24.

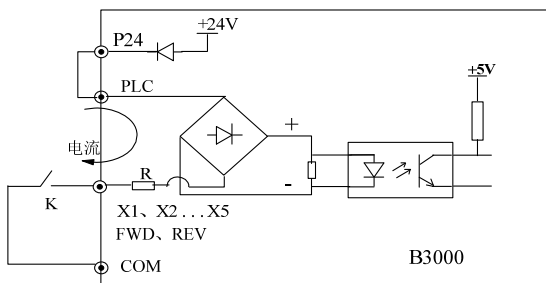

If you require an external power supply, make sure to disconnect the cable between terminals PLC and P24, as shown below.

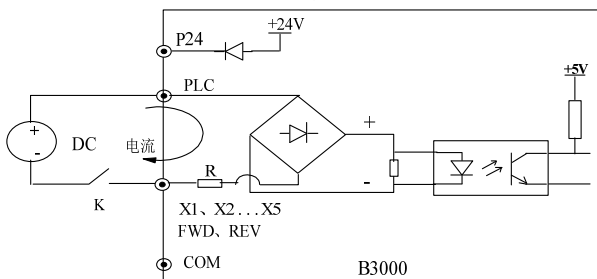

Figure 3-13 External power supply wiring diagram

### ② Connection Method 2

Inverter's internal +24V power supply is used and the external controller uses PNP transistors whose common emitters are connected, as shown in Figure 3-14.

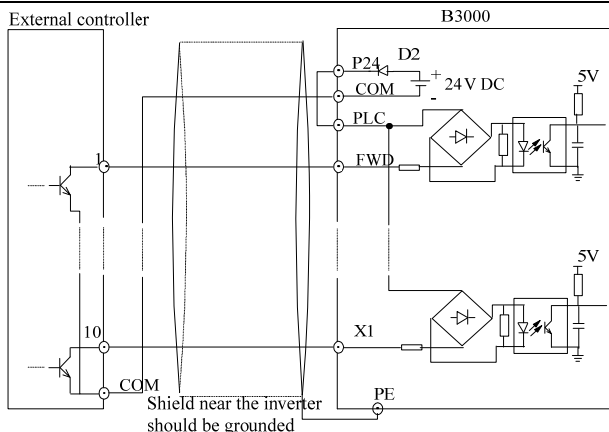

Figure 3-14 Internal +24V wiring diagram (source)

Inverter's internal +24V power supply is used and the external controller uses PNP transistors whose common emitters are connected. (Remote the wire between PLC and P24) .

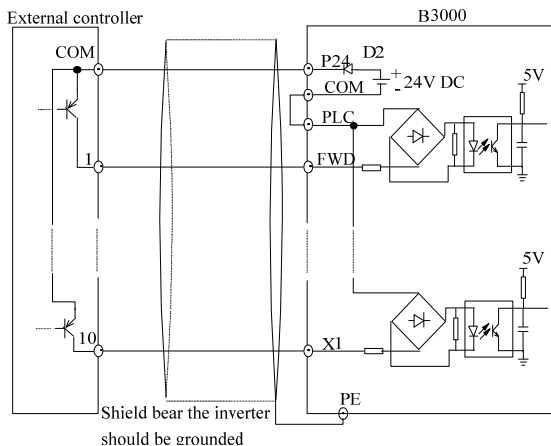

Figure 3-15 Internal +24V wiring diagram (drain)

When using External power supply, remember to disconnect PLC and P24

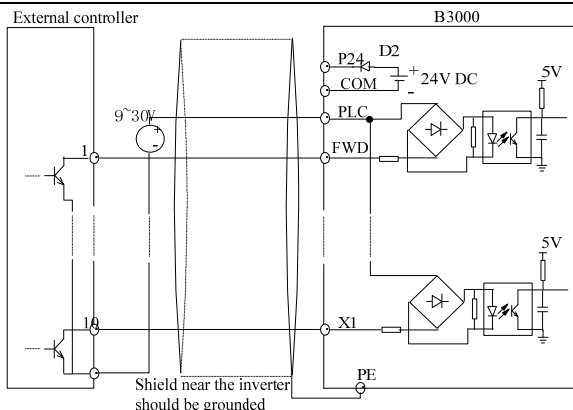

Figure 3-16 External power supply wiring (source)

External power supply wiring (drain)(Remember to disconnect PLC and P24)

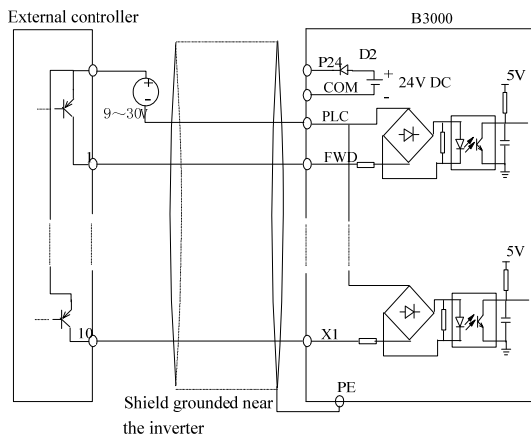

Figure 3-17 External power supply wiring (drain)

### 5) Multi-function Output Terminal Wiring

- ① Terminal Y1 can use the internal 24V power supply, see the figure below:

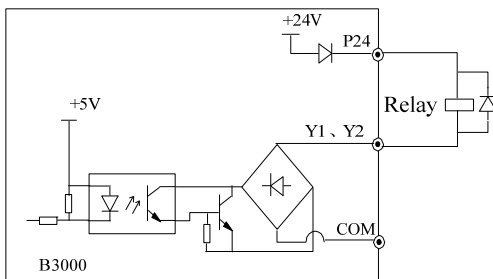

Figure 3-18 Multi-function output terminal wiring 1

- ② Terminal Y1 can also use external power (9~30V) supply:

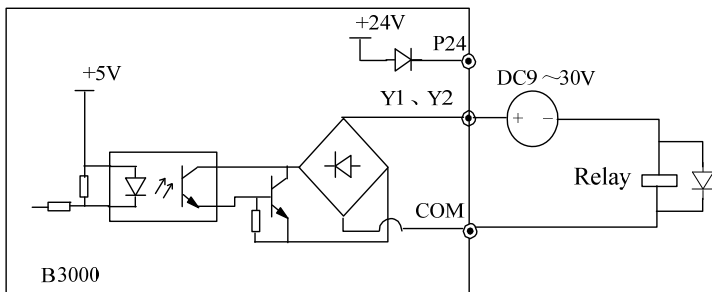

Figure 3-19 Multi-function output terminal wiring 2

- ③ When Terminal Y2 is used as digital pulse frequency output, it can also use the internal 24V power supply:

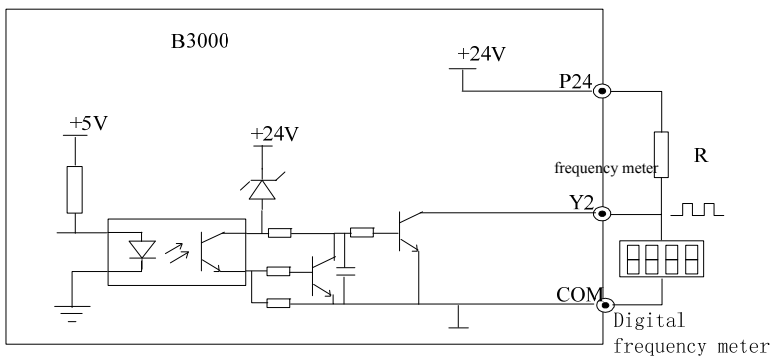

Figure 3-20 Terminal Y2 wiring 1

- ④ When Terminal Y2 is used as digital pulse frequency output, it can also use the external power supply (9~30V):

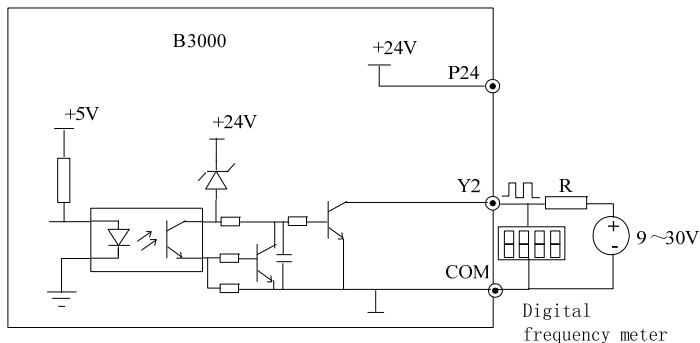

Figure 3-21 Terminal Y2 wiring 2



**Note:**

- 1 . Don't short terminals P24 and COM, otherwise the control board may be damaged.
- 2 .Use multi-core shielded cable or multi-strand cable (above 1mm) to connect the control terminals.
- 3 . When using a shielded cable, the shielded layer's end that is nearer to the inverter should be connected to PE.
- 4 . The control cables should be as far away (at least 20cm) as possible from the main circuits and high voltage cables (including power supply cables, motor cables, relay cables and cables of contactor). The cables should be vertical to each other to reduce the disturbance to minimum.

**5.2.4 Onsite Wiring Requirements**

To avoid mutual EMI disturbance, the control cables, power cable and motor cable should be installed as apart as possible, especially when they are routed in parallel for rather long distance. If the signal cable must cross the power cable or motor cable, keep them at right angle to each other.

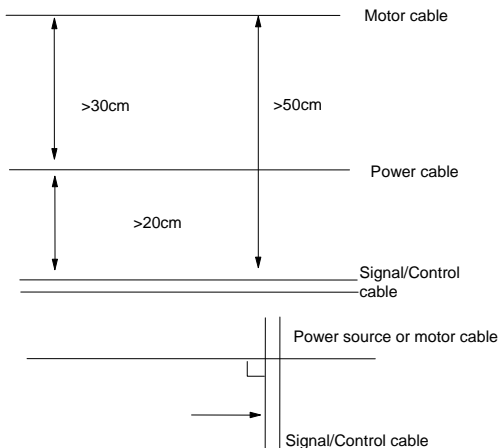

Figure 3-22 Cable routing schematic diagram

If the section area of the motor cable is too big, the motor should derate. Refer the inverter's cable specs in Table 3-2. Since the larger the section area of cables, the greater their capacitance to the ground, therefore, the output current should derate 5% with increasing every category of cable section area. Shielded/armored cable: high-frequency low-impedance shielded cable should be used, such as woven copper mesh, aluminum mesh or metal mesh.

## Users Manual

The control cable should be shielded, and the clamps at both ends of the metal mesh should be connected to the earth terminal of the inverter enclosure.

Use conductive plate and dentate pad to clear away the paint between the screws and metal casing, to ensure good conductivity.

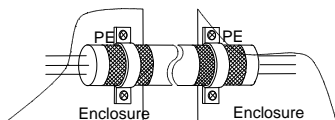

Figure 3-23 Correct shield layer earthing

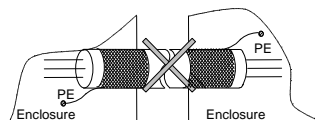

Figure3-24 Incorrect shield layer earthing

### 5.2.5 Earthing

Independent earthing pole (recommended)

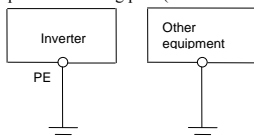

Figure 3-25 Earthing Diagram 1

Shared earthing pole (acceptable)

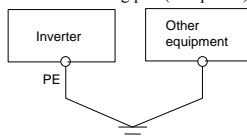

Figure 3-26 Earthing Diagram 2

Shared earthing lines (not allowed)

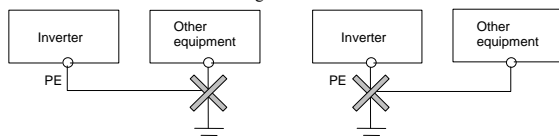

Figure 3-27 Earthing Diagram 3

Besides, pay attention to the following points:

In order to reduce the earthing resistance, flat cable should be used because the high frequency impedance of flat cable is smaller than that of round cable with the same CSA.

For 4-core motor cable, the end of one cable should be connected to the PE of the inverter, and the other end should be connected to the motor's enclosure. If the motor and the inverter each have its own earthing pole, then the earthing effect is better.

If the earthing poles of different equipment in one system are connected together, then the leakage current will be a noise source that may disturb the whole system. Therefore, the inverter's earthing pole should be separated with the earthing pole of other equipment such as audio equipment, sensors and PC, etc.

In order to reduce the high frequency impedance, the bolts used for fixing the equipment can be used as the high frequency terminal. The paints on the bolt should be cleaned.

## **Users Manual**

---

The earthing cable should be as short as possible, that is, the earthing point should be as close as possible to the inverter.

Earthing cables should be located as far away as possible from the I/O cables of the equipment that is sensitive to noise, and lead should also be as short as possible.

## 6. Operation Procedures

### 6.1 Operation Guide

#### 6.1.1 LED Keypad

LED keypad display unit is to receive command and display parameters.

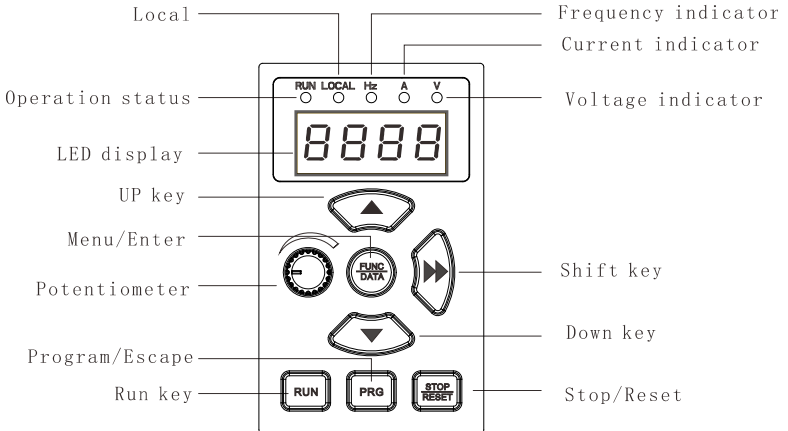

Keypad diagram of B3000-2S0004G~4T0022G

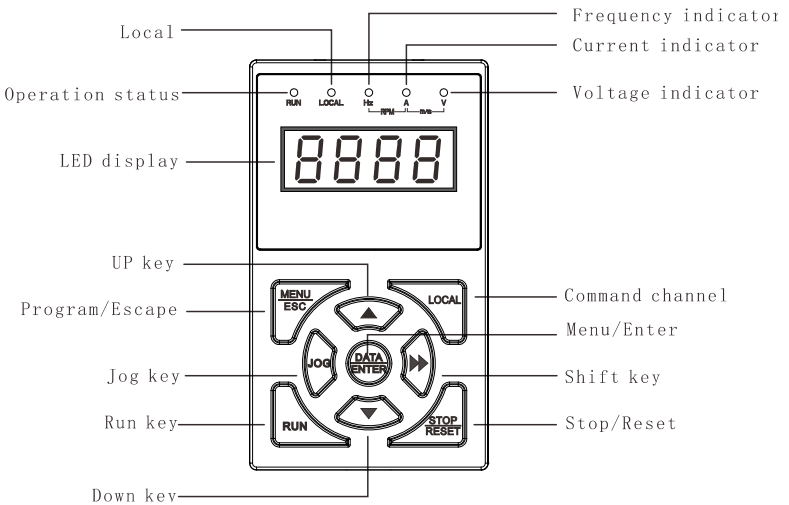

Keypad diagram of B3000-4T004.0G

Figure 4-1 LED Keypad Display Unit

### 6.1.2 Keypad Function Explanation

Keys on the LED keypad display unit refer to the function of each key in Table 4-1.

Table 4-1 Key's function of B3000-2S0004G~4T0022G

Key	Name	Function
PRG	Program/Esc key	To shift between program state and Esc state
FUNC/DATA	Function/Data key	To shift between function code menus, confirm modification
▲	Increase key	To increase data or function code number
▼	Decrease key	To decrease data or function code number
▶▶	Shift key	To scroll over the displayed parameters, such as voltage、 frequency. To select the digit to be modified
RUN	Run key	In the keypad operating mode, press the key to start running
STOP/RESET	Stop/Reset key	In keypad mode, stop the inverter or reset in case of alarm or fault; Terminal control mode: reset in case of alarm or fault
/	Potentiometer	Set frequency

Key's function B3000-4T0040G/0075P~4T8000G

Key	Name	Function
MENU/ESC	Program/Esc key	To shift between program state and Esc
ENTER/DATA	Function/Data key	To enter sub-menu, confirm modification
▲	Increase key	To increase data or function code number
▼	Decrease key	To decrease data or function code number
▶▶	Shift key	In the edit state, you can select the modified bit of set digit; In other state, to scroll over the displayed parameters.
LOCAL	Control mode	Control mode selection, press ENTER/DATA to confirm
JOG	Jog key	In panel control mode, press Jog to start running
RUN	Run key	In panel control mode, press the key to start running.
STOP/RESET	Stop/Reset key	Reset in case of alarm or fault

### 6.1.3 Indicator Description

Functions of the indicators on the keypad:

## Users Manual

Indicator	Meaning	Color	Mark
Status indicator	ON: the inverter is running	Green	RUN
Frequency indicator	ON: current LED display is frequency	Green	Hz
Current indicator	ON: current LED display is current	Green	A
Voltage indicator	ON: current LED display is voltage	Green	V
Control mode indicator	ON, keypad control mode; OFF: terminal control mode; Flicker: communication control mode	Green	LOCAL
Potentiometer	Set frequency by the potentiometer	Green	None

Implication of the combination of indicators:

Indicator combination	Meaning
Hz+A	Set speed (rpm)
A+V	Set line speed (m/s)
Hz+V	Set percentage (%)

If all the above indicators (A, V, Hz) go out, it means the displayed parameter has no unit.

### 6.1.4 Parameter Setting Method

B3000 series inverter adopts three-level menu structure, a menu for the group number, the secondary menu for the function code, three menus for the function code corresponding value.

Parameter settings are divided into two decimal and hexadecimal, if the parameter uses hexadecimal notation, when you edit independently.

Example 1: P2.01 transferred by the 0.2Hz 0.5Hz (decimal)

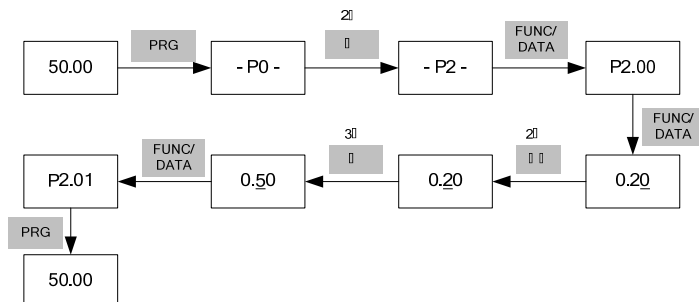

## Users Manual

Example 2: PA.00 (running display parameter 1) to display the output frequency (before compensation), set frequency, output current, output torque (hexadecimal).

Binary and hexadecimal number conversion table shown in Table 5-12.

Bit values: 1101, converted to hexadecimal d.

Ten values: 0000, converted to hexadecimal zero.

One hundred value: 0010, converted to hexadecimal 2.

One thousand value: 0000, converted to hexadecimal zero.

PA.00 should be set 020d.

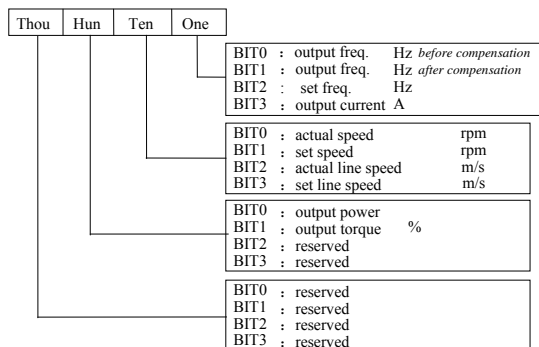

### 6.1.5 Fault reset

After the inverter fault message, locking in fault state, if the fault is not reset, you can not run. You can use the STOP / RESET button or terminal reset function on the keyboard fault reset. After the reset, the drive is in standby mode, it can run again.

### 6.1.6 Motor parameter self-learning

In order to obtain good dynamic and static control performance, the need for motor parameters from the study, as follows:

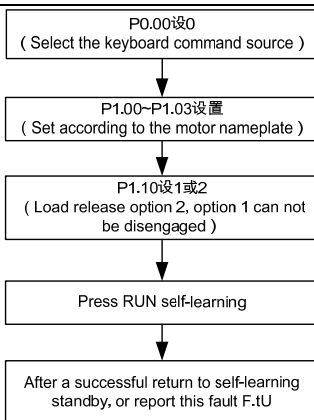

### 6.17 Password Settings

When the user needs a password-protected, PP.00 set to a non-zero value, exit edit mode, for 5 minutes without operation, the password becomes effective; press PRG again to enter the function code is set, it will display 0.0.0.0, need to enter this password to enter. If users want to cancel the password protection, it will be set to 0 PP.00.

### 6.18 Operation Mode Selection Priority

B3000 inverter operation mode, in descending order of priority:

Jog run → closed-loop run mode Run mode → PLC → multi-speed operation mode → Normal operating mode.

### 6.19 The main priorities set frequency

Descending order of priority:

Jog frequency frequency → closed-loop run → PLC run → multi-speed running frequency frequency → Normal operation frequency.



## 7. Parameters

### Note:

The contents in the “**【】**” are factory default.

### 7.1 Basic Parameters (P0)

P0.00	Command channel	Range: 0~2 <b>【0】</b>
-------	-----------------	-----------------------

B3000 has 3 kinds of command channels:

0: LED keypad display unit, use RUN and STOP key on the keypad to control the inverter.

1: Terminal control: Input operating commands via terminals. Use terminals FWD, REV, to start and stop the inverter

2: Serial communication port control.

P0.01	Control mode	Range: 0~1 <b>【0】</b>
-------	--------------	-----------------------

0: Vector control 1

1: Vector control 2

P0.02	Frequency source setting	Range: 0~6 <b>【0】</b>
-------	--------------------------	-----------------------

0: Digital setting 1, set by ▲ or ▼ key.

Initial frequency is the value of P0.04 and it can be adjusted via ▲ and ▼ keys on the keypad.

1: Digital setting 2 set by terminal UP/DN.

Initial frequency is the value of F0.02 and it can be adjusted via terminal UP/DN.

2: Digital setting 3, set through serial communication port

Initial frequency is the value of P0.04 and it can be adjusted via serial communication port.

3: VCI

The reference frequency is set by voltage input via terminal VCI and the input voltage range is DC 0~10VDC.

4: CCI

The reference frequency is set by voltage or current input via terminal CCI and the input range is DC 0~10 VDC (if jumper CN7 (SW1) is placed at V side) or DC0~20mA (if jumper CN7 (SW1) is placed at I side).

5: Terminal Pulse Setting

The reference frequency is set by terminals X4 or X5, see P5.03~P5.04. The input pulse range: 15~30V, 0~50.0 kHz.

6: Keypad Potentiometer Setting (for power lower than B3000-4T0040G)

## Users Manual

The reference frequency is set by potentiometer, the adjusting range is 0~Max (P0.09).

### Note :

For method 3, 4 and 5, the frequency calculation curve is given in P5.10~P5.21, please refer to 5.5.

P0.03	Auxiliary reference frequency	Range: 00~13 【0】
-------	-------------------------------	------------------

The setting frequency of B3000 is composed of main reference frequency and auxiliary reference frequency. P0.03、P0.05、P9.17、P9.18 are used to define auxiliary reference frequency. Figure 5-1 shows the formation process of setting frequency.

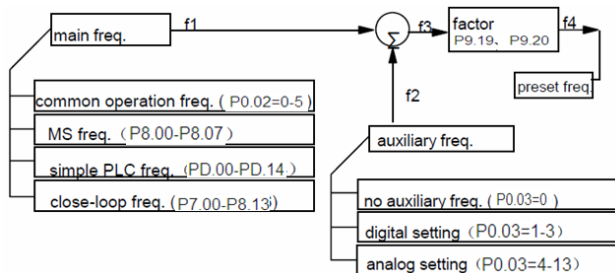

Figure 5-1 Preset Freq. Calculation Method

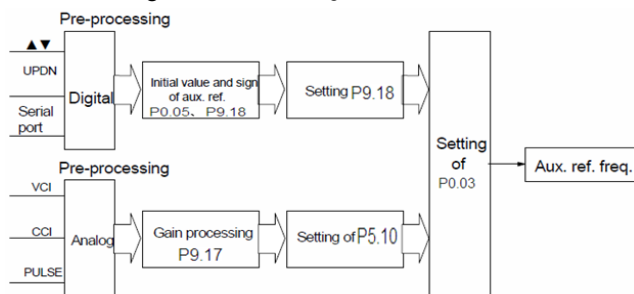

Figure 5-2 Auxiliary Frequency Processing

Table 5-1 Auxiliary reference frequency method selection

Method	Name	Description
0	invalid	Auxiliary freq.=0
1	Adjust by ▲ and ▼	Set by P0.05
2	Adjust UP/DN	
3	Set by serial port	
4	VCI	Depending on actual input. Refer to P5. 10
5	CCI	
6	PULSE	
7	- VCI	
8	- CCI	

## Users Manual

Method	Name	Description
9	- PULSE	
10	VCI-5	
11	CCI-5	
12	PULSE-0.5×Max pulse input freq.	
13	Potentiometer ( for power lower than B3000-4T0040G)	

Select digital setting 3, you may set P0.03 via serial port to change auxiliary frequency.

If VCI-5 or CCI-5 is selected, take 5V input as the point corresponding to zero frequency, 0~5V input corresponds to negative output, 5~10V input corresponds to positive output. See Figure5-3.

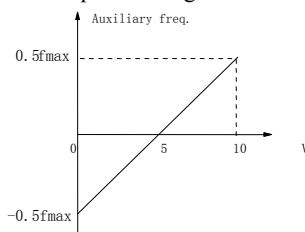

$f_{max}$ —frequency corresponding to Max analog value(P5.17 or O5.21)

Figure 5-3 Frequency Setting Via VCI-5 or CCI-5

If PULSE-0.5 × P5.13 is taken as auxiliary frequency setting method, one half of P5.13 (max. pulse freq.) as the point corresponding to zero frequency, 0~0.5 times of F1.03 input corresponds to negative output, 0.5~1 times of P5.13 input corresponds to positive output. See Figure5-4.

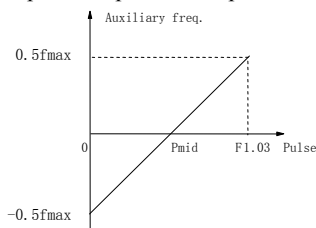

$P_{mid} = 1/2 * P5.13$

$f_{max}$ —frequency corresponding to Max analog value (p5.17 or P5.21)

Figure 5-4 PULSE-0.5 × P5.13 As Freq. input

F9.17: Analog auxiliary reference factor

It is valid when F0.03=4~12. The auxiliary reference undergoes F9.17 gain calculation first, and then output according to F5.10.

## Users Manual

P9.18: digital auxiliary reference control

It is valid when P0.03=1~3. See Figure 5-5.

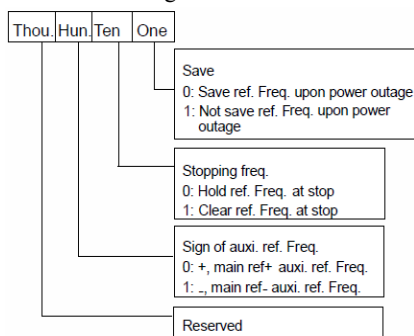

Figure 5-5 Digital Auxiliary Freq. Setting

One's place of P9.18

0: save the auxiliary freq. at power off

The auxiliary frequency will be saved in P9.03, and the sign of the freq. saved in P9.18.

1: not save the auxiliary freq. at power off

Ten's place of P9.18

0: maintain the auxiliary freq. if the inverter stops

1: preset frequency is cleared if the inverter stops

Hundred's place of P9.18: sign of auxiliary freq.

0: (+) positive sign.

Preset freq. is the sum of main freq. and auxiliary freq.

1: (−) negative sign

Preset freq. is the result of main freq. minus auxiliary freq.

### Note:

When the inputting mode of auxiliary reference frequency is the same with that of main reference frequency, the auxiliary reference frequency setting is invalid.

P0.04 Keypad digital setting	Range: Lower limit of freq.~Upper limit of freq. 【50.00Hz】
------------------------------	--

When the frequency source setting method is defined as keypad digital setting(P0.02=0、1、2), P0.04 is the initial value of frequency.

P0.05 Digital auxiliary frequency	Range: 0.00~650.00Hz 【0.00Hz】
-----------------------------------	-------------------------------

P0.05: The initial value of digital auxiliary frequency.

## Users Manual

It is valid only and it is the initial value of auxiliary frequency when P0.03=1~3.

P0.06	Base frequency	Range: 0.00~650.00Hz 【50.00Hz】
P0.07	Upper limit of freq.	Range: Upper limit~Max output freq. 【50.00Hz】
P0.08	Lower limit of freq.	Range: 0~Upper limit of freq. 【0.00Hz】

Please refer  $f_H$  and  $f_L$  in Figure 5-6

P0.09	Max output frequency	Range: Max {50.00, P0.12 upper limit of frequency} ~650.00H 【50.00Hz】
P0.10	Max output voltage	Range: 1~480V 【Inverter's rated】

The max frequency refers to the allowed max output frequency of the inverter. Refer to the  $f_{max}$  in Figure 5-6;

Base frequency normally corresponds with the rated frequency of the motor. It is the Min frequency when the inverter outputs the highest voltage, as shown in Figure 5-6 as  $f_b$

Max output voltage is the inverter's output voltage when the inverter outputs base frequency, as shown in Figure 5-6 as  $V_{max}$ . This corresponds to the rated voltage of the inverter

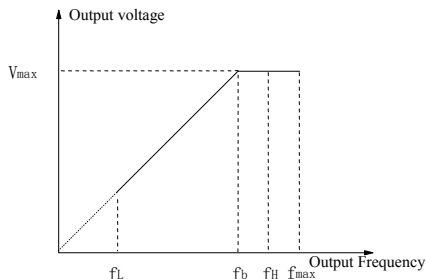

Figure 5-6 Characteristic parameters definition

The  $f_H$  and  $f_L$  are defined by P0.07 and P0.08 as upper limit and lower limit of frequency respectively.

P0.11	Running directions	Range: 0、1 【0】
-------	--------------------	----------------

The function applies only to keypad control, but not serial port control, not terminal control mode.

0: Forward

1: Reverse

P0.12	Acc time 1	Range: 0.1~3600s (min) 【6.0s/20.0S】
P0.13	Dec time 1	Range: 0.1~3600s (min) 【6.0s/20.0S】

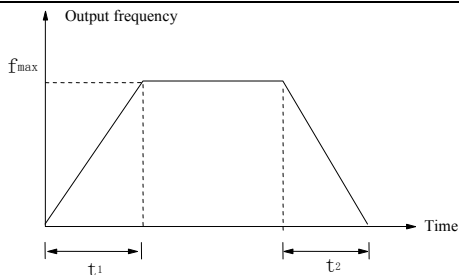

Figure 5-7 Acc/Dec time definition

Acc time is the time taken for the motor to accelerate from 0 Hz to the maximum frequency (as set in P0.09), see  $t_1$  in Figure 5-7. Dec time is the time taken for the motor to decelerate from maximum frequency (P0.09) to 0 Hz, see  $t_2$  in Figure 5-7.

B3000 has four pairs of Acc/Dec time. Here we only introduce Acc/Dec time

1. Please find acc/dec time 2~4 in section 5.9: P8.14~P8.19

P0.14 Anti-reverse setting	range: 0、1 【0】
----------------------------	----------------

0: Reverse allowed

1: Reverse not allowed

## 7.2 Motor Parameter (P1)

P1.00 Model	Range: 0、1 【0】
-------------	----------------

0: G model (Constant torque)

1: P model (Pump & Fan)

### Note:

For power lower than B3000-4T0040G , P1.00 is reserved.

P1.01 Motor's poles	Range: 2~14 【4】
P1.02 Rated power	Range: 0.4~999.9kW【depending on model】
P1.03 Rated current	Range: 0.1~999.9A【depending on model】

P1.01~P1.03 are to set motor's parameters. Be sure to input the values according to motor's nameplate.

P1.04 Current without load	Range: 0.1~999.9A【depending on model】
P1.05 Stator resistance	Range: 0.0~50.00%【depending on model】
P1.06 Leakage inductance	Range: 0.0~50.00%【depending on model】

## Users Manual

P1.07 Rotor resistance	Range: 0.0~50.00% 【depending on model】
P1.08 Mutual inductance	Range: 0.0~2000.0% 【depending on model】

Please refer the above parameters to Figure 5-8.

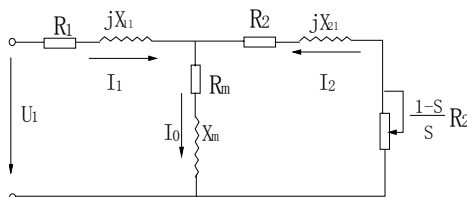

Figure 5-8 Motor's Equivalent Circuit

In Figure 5-8,  $R_1$ ,  $X_{1l}$ ,  $R_2$ ,  $X_{2l}$ ,  $X_m$  and  $I_0$  represent stator's resistance, stator's leakage inductance, rotor's resistance, rotor's leakage inductance, mutual inductance and current without load respectively. The setting of P1.06 is the sum of stator's leakage inductance and rotor's inductance.

The settings of P1.05 ~P1.08 are all percentage. Formula used for calculating stator's resistance or rotor's resistance::

$$\%R = \frac{R}{V/(\sqrt{3} \cdot I)} \times 100\%$$

R: Stator's resistance or rotor's resistance that is converted to the stator's side;

V: Rated voltage;

I: Motor's rated current;

Formula for calculating (leakage inductance or mutual inductance);

$$\%X = \frac{X}{V/(\sqrt{3} \cdot I)} \times 100\%$$

X: The sum of leakage inductance of stator and rotor, or mutual inductance.

The rotor's inductance has been converted to the stator's side;

V: Rated voltage;

I: Motor's rated current

If motor's parameters are available, please set P1.05 ~P1.08 to the values calculated according to the above formula.

If the inverter performs auto-tuning of motor's parameters, then the settings of P1.04~P1.08 after the auto-tuning process will be updated.

After motor power (setting of P1.02) is changed, the inverter will set P1.03~P1.08 to corresponding parameters.

P1.09 Rated slip frequency	Range: 0.00~20.00Hz 【2.00Hz】
----------------------------	------------------------------

Motor's rated slip frequency can be calculated by the motor's rated speed (on the nameplate):

## Users Manual

---

Rated slip frequency = motor's rated frequency (i.e. basic operating frequency P0.06) × (motor's synchronous speed-motor's rated speed) ÷ motor's synchronous speed. Where: motor's synchronous speed = motor's rated frequency × 120 ÷ number of motor's poles (P1.01)

After setting the slip frequency, the slip compensation will be enabled by P3.09~P3.11.

P1.10	Auto tuning	Range: 0~2 【0】
-------	-------------	----------------

FH09 can be used to measure and write-in the motor's parameters automatically.

0: Auto-tuning is disabled

1: Stationary auto-tuning (Start auto-tuning to a standstill motor)

Before starting auto-tuning, values on the motor's nameplate must be input correctly (P1.01~P1.03). When starting auto-tuning to a standstill motor, the stator's resistance, rotor's resistance and the leakage inductance will be measured and the measured values will be written into P1.05, P1.06 and P1.07 automatically.

2: Rotating auto-tuning

When starting a rotating auto-tuning, at first, the motor is in standstill status, and the stator's resistance, rotor's resistance and the leakage inductance will be measured, and then the motor begins to rotate, mutual inductance, parameters will be measured and written into P1.05, P1.06, P1.07, P1.08 and P1.04 automatically.

After auto-tuning, P1.10 will be set to 0 automatically.

Auto-tuning procedures:

- 1) Set the "P0.06 basic operating frequency" and "P0.07 Max output voltage" correctly according to the motor's feature;
- 2) Set the P1.01, P1.02 and P1.03 correctly;
- 3) If P1.10 is set to 2, Acc time (P0.12) and Dec time (P0.13) should be set correctly and remove the load from the motor and check the safety;
- 4) Set P1.10 to 1 or 2, press **FUNC/DATA**, and then press **RUN** to start auto-tuning;
- 5) When the operating LED turns off, that means the auto-tuning is over.

---

### Note :

- 1 . When setting P1.10 to 2, you may increase Acc/Dec time if over-current or over-voltage fault occurs in the auto-tuning process;
  - 2 . When setting P1.10 to 2, the motor's load must be removed before starting rotating auto-tuning;
  - 3 . The motor must be in standstill status before starting the auto-tuning, otherwise the auto-tuning cannot be executed normally;
-



- 4 . If it is inconvenient to start auto-tuning (e.g. the motor cannot break away from the load), or you don't require much on motor's control performance, you can use stationary auto-tuning or even disable the function. You may input the values on the motor's nameplate correctly (P1.01~P1.03);
- 5 . If the auto-tuning function is unavailable and there is motor's parameters on the nameplate, you should input the values correctly (P1.01~P1.03), and then input the calculated values (P1.04~P1.08). Please set the parameters correctly;
- 6 . If auto-tuning is not successful, the inverter alarms and displays fault F.tU.

### 7.3 Start/Brake Parameter (P2)

P2.00 Start mode	Range: 0、1、2 【0】
------------------	------------------

P2.00=0: Start at start frequency

The inverter is started at start frequency (P2.01) and in preset time (P2.02) .

P2.00=1: Brake first and then start at start frequency.

DC brake first, refer to P2.03、 P2.04, and then start in the manner of P2.00=0

P2.00=2: Rotate speed tracking and then start at start frequency (For power lower than B3000-4T0040G, P2.00 is reserved)

Tracking motor's rotate speed and directions automatically. Start the motor during rotating smoothly and without any impact. Please refer to Figure 5-a.

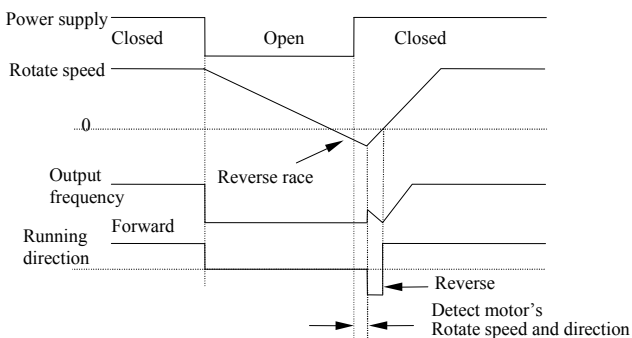

Figure 5—a

#### Note :

- 1 . Start mode 1 applies to small-inertia motor when the inverter stops, the motor is still rotating. For large-inertia load, do not restart until the motor stops.
- 2 . Start mode 2 applies to large-inertia motor when the inverter stops, the motor is still running.

## Users Manual

- 3 . The performance of start mode 2 is related to motor parameters. Please set the parameters of PH correctly.
- 4 . When driving synchronized motor, it is recommended to use start mode 0.

P2.01 Start frequency	Range: 0.20~60.00Hz 【0.20Hz】
P2.02 Start frequency hold time	Range: 0.0~10.0s 【0.0s】

Start frequency refers the frequency at which the inverter starts, as shown in Figure 5-9 as  $f_s$ . Start frequency hold time refers the time within which the inverter runs at start frequency during start up, as shown in Figure 5-9  $t_1$ .

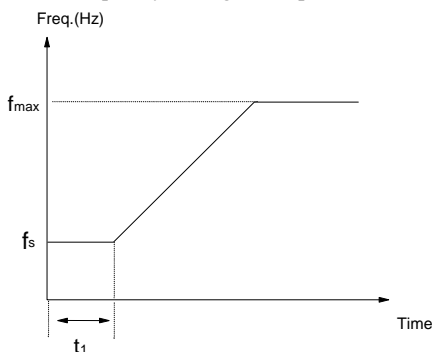

Figure 5-9 Relation of Start Freq. and Start Time

### Note:

The start frequency is not limited by lower limit of the frequency.

P2.03 DC brake current at startup	Range: Depending on model 【0.0%】
P2.04 DC brake time at startup	Range: Depending on model 【0.0s】

P2.03 and P2.04 are valid only when you set P2.00=1, that is, braking before starting. See Figure 5-10.

DC brake current at startup is determined by inverter model,

4.0KW and below G type: 0~150%; P type: 0~130%。

5.5KW and above G type: 0~100%; P type: 0~80%。

DC braking current start up is relative to the percentage of the rated current of the inverter.

If the brake time at startup is set to 0.0s, no brake process.

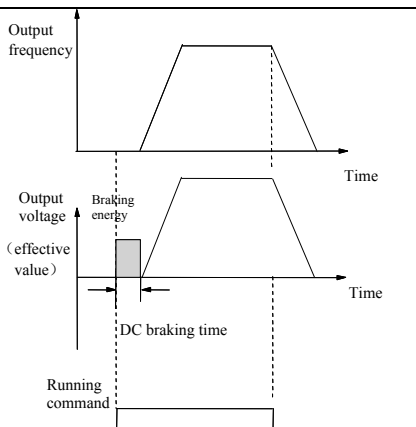

Figure 5-10 Start mode 1

P2.05 Acc/Dec	Range: 0、1 【0】
---------------	----------------

P2.05=0: Linear Acc/Dec

The output frequency increase or decrease according to a fixed slope, see Figure 5-11.

P2.05=1: S curve Acc/Dec

The output frequency increase or decrease according to S curve, see Figure 5-12.

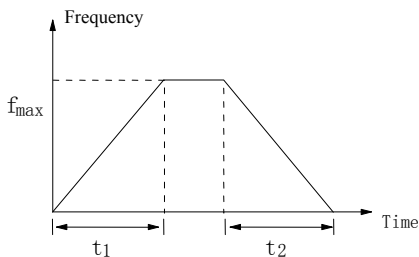

Figure 5-11 Linear Acc/Dec curve

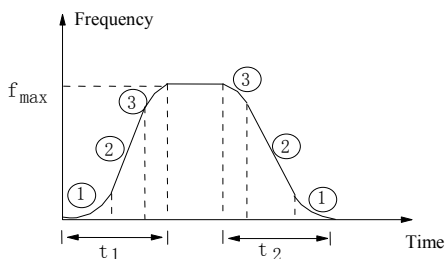

Figure 5-12 Acc/Dec S curve

## Users Manual

P2.06 S curve start time	Range: 10~50% <b>【20.0%】</b>
P2.07 S curve rising time	Range: 10~80% <b>【60.0%】</b>

P2.06、P2.07 are only valid when F2.05=1 (S curve mode) and  $P2.06+P2.07 \leq 90\%$ .

S curve start time is illustrated in Figure 5-12 as ①, the change rate of output frequency is increasing from 0.

S curve rising time is illustrated in Figure 5-12 as ②, the change rate remains the same.

S curve end time is illustrated in Figure 5-12 as ③. The change rate decreases to 0.

S curve Acc/Dec is suitable to the start and stop of elevator, conveyer, etc.

P2.08 Stop mode	Range: 0、1、2 <b>【0】</b>
-----------------	-------------------------

0: Decelerate to stop

When the inverter receives Stop command, it will reduce output frequency to zero and stop within preset deceleration time.

1: Coast to stop

When the inverter receives Stop command, it will stop outputting frequency and stop gradually relying on load inertia.

2: Deceleration + DC braking

When the inverter receives Stop command, it will reduce output frequency within preset Dec time. When it arrives at the frequency threshold of DC braking, the DC braking begins. Please refer to P2.09~P2.12.

P2.09 Frequency threshold of DC braking	Range: 0.00~60.00Hz <b>【1.00Hz】</b>
P2.10 DC brake delay time	Range: 0.00~10.00s <b>【0.00s】</b>
P2.11 DC brake current	Range: Depending on model <b>【120.0%/100.0%】</b>
P2.12 DC brake time at stop	Range: Depending on model <b>【0.5s】</b>

DC braking delay time is the period from arriving at frequency threshold (P2.09) to starting braking.

During the period, there is no output from the inverter. This function can prevent current overshoot of high power motor at startup.

For power lower than B3000-4T0040G:

The braking current is different depending on inverter's model, G type: 0~150% of inverter's rated current (max. current among the 3 phases), P type: 0~130% of inverter's rated current (max. current among the 3 phases).

For power higher than B3000-4T0055G/0075P:

The braking current is different depending on inverter's model, G type: 0~150% of inverter's rated current (max. current among the 3 phases), P type: 0~130% of inverter's rated current (max. current among the 3 phases).

## Users Manual

If the brake time at stop is set at 0.0s, there is no braking process.

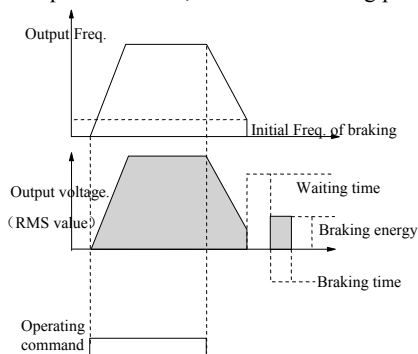

Figure 5-13 Deceleration +DC braking Process

P2.13 Dynamic braking	Range: 0, 1 <b>【0】</b>
-----------------------	------------------------

0: Disabled

1: Enabled

### Note :

Please set this parameter properly according to your needs, otherwise, the control performance will be suffered.

P2.14 Ration of braking time to total operating time	Range: 0.0~100.0% <b>【100.0%】</b>
--	-----------------------------------

The max. Continuous dynamic braking time is calculated with 100s as a cycle.

### Note :

The resistance and power of the braking resistor should be considered.

## 7.4 Flux vector control parameters (P3)

P3.00 V/F curve setting	Range: 0~3 <b>【0】</b>
P3.01 V/F freq. F3	Range: P3.03~P0.06 <b>【0.00Hz】</b>
P3.02 V/F voltage V3	Range: P3.04~100.0% <b>【0.0%】</b>
P3.03 V/F freq. F2	Range: P3.05~P3.01 <b>【0.00Hz】</b>
P3.04 V/F voltage V2	Range: P3.06~P3.02 <b>【0.0%】</b>
P3.05 V/F freq. F1	Range: 0~P3.03 <b>【0.00Hz】</b>
P3.06 V/F voltage V1	Range: 0~P3.04 <b>【0.0%】</b>

This group of parameters defines the V/F setting modes so as to satisfy the requirements of different loads. Three fixed curves and one user-defined curve can be selected according to the setting of P3.00.

If P3.00 is set to 1, a 2-order curve is selected, as shown in Figure 5-14 as curve 1;

## Users Manual

If P3.00 is set to 2, a 1.7-order curve is selected, as shown in Figure 5-14 as curve 2;

If P3.00 is set to 3, a 1.2-order curve is selected, as shown in Figure 5-14 as curve 3.

The above V/F curves are suitable for the variable-torque loads such as fan & pumps. The user can select the curves according to the actual load so as to achieve the best energy-saving effects.

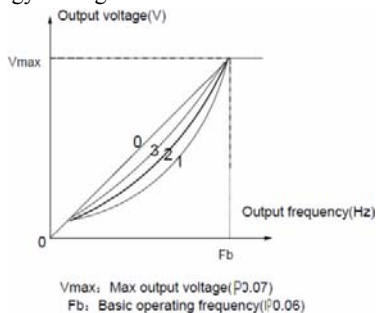

Figure 5-14 Torque-reducing curve

If P3.00 is set to 0, you can define a curve by P3.01~P3.06, i.e. a polygonal line defined by 3 points (V1, F1), (V2, F2), (V3, F3), to satisfy the needs of special loads, as shown in Figure 5-15.

The default is a straight line, shown in Figure 5-14 as curve 0.

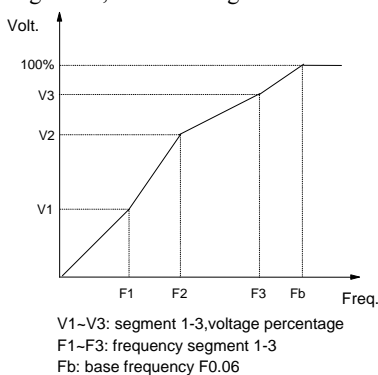

Figure 5-15 User Defined V/F curve

P3.07 Torque boost	Range: 0~30.0% 【0.0%】
--------------------	-----------------------

In order to compensate the torque drop at low frequency, the inverter can boost the voltage so as to increase the torque. If F0.09 is set to 0, auto torque boost is enabled and if set at non-zero, manual torque boost is enabled, as shown in Figure 5-16.

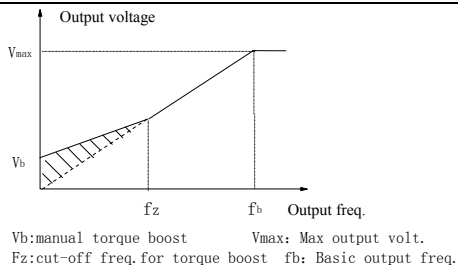

Figure 5-16 Torque boost (shadow area: boost value)

**Note:**

- 1 . Wrong parameter setting can cause overheating of the motor or triggers the over-current protection of the inverter.
- 2 . Refer to P3.08 for definition of fz.
- 3 . When using synchron motor, you should select manual torque boost, and adjust V/F curve according to the motor parameters and application.

P3.08 Manual torque boost cutoff point	Range: 0~50% 【10.0%】
--	----------------------

P3.08 defines the ratio of the cut-off frequency used for manual torque boost to the base frequency (defined by P0.06) , as shown in Figure 5-16 as fz. This cut-off frequency adapts to any V/F curve defined by P3.00.

P3.09 Slip compensation gain	Range: 0.0~300.0% 【100.0%】
P3.10 Slip compensation limit	Range: 0.0~250.0% 【200.0%】
P3.11 Compensation time	Range: 0.1~25.0s 【2.0s】

The change in motor torque will affect motor slip and result in speed change. Through slip compensation, the output frequency can be adjusted according to motor load torque, so as to reduce speed change caused by load change. See Figure 5-17.

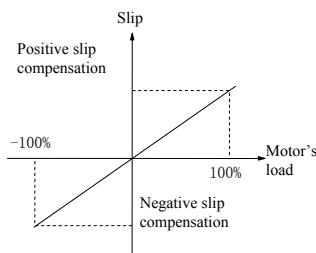

Figure 5-17 Auto slip compensation

Electromotion state: Increase the gain of slip compensation gradually when the actual speed is lower than the reference speed (P3.09)

## Users Manual

Power generation state: Increase the gain of slip compensation gradually when the actual speed is higher than the reference speed (P3.09).

Slip compensation range: limit of slip compensation (P3.10) × rated slip (P1.09).

### Note :

The value of automatically compensated slip is dependent on the motor's rated slip; therefore the motors rated speed must be set correctly (P1.09).

P3.12 AVR function	Range: 0、1、2 【2】
--------------------	------------------

0: Disabled

1: Always enabled

2: Disabled during decelerating

AVR: auto voltage adjustment. This function can keep constant output voltage when the input voltage deviates from rated value. Therefore, the function should be enabled all the time especially when the input voltage is higher than the rated value.

If AVR is disabled during deceleration, the Dec time is shorter but the current is higher, otherwise, the motor decelerates smoothly with lower current, but the Dec time is longer.

P3.13 Auto energy saving	Range: 0、1 【0】
--------------------------	----------------

0: Disabled

1: Enabled

The inverter can detect load current and adjust voltage accordingly to save energy.

### Note :

This function is preferable to the load such as fan and pump.◦

P3.14 Motor stabilization factor	Range: 0~255 【Depending on model】
----------------------------------	-----------------------------------

P3.14 is used to suppress the oscillation caused by the inverter and the motor. If the inverter's output current changes constantly at fixed load, the oscillation can be reduced by adjusting P3.14.

For power lower than 55kW, the default value is 10;

For power higher 55kW, the default value is 20.

## 7.5 Current vector control parameter (P4)

P4.00 Reserved	-
----------------	---



**Users Manual**

P4.01	Pre-excitation	Range: 0~1 <b>【1】</b>
0: Valid		
1: Invalid		
P4.02	Speed loop proportional gain 1	Range: 0~65535 <b>【120】</b>
P4.03	Speed loop integral gain 1	Range: 0~65535 <b>【3】</b>
P4.04	Speed loop proportional gain 2	Range: 0~65535 <b>【120】</b>
P4.05	Speed loop integral gain 2	Range: 0~65535 <b>【3】</b>
P4.06	Speed loop switching frequency	Range: 0.0%~100.0% <b>【3】</b>
P4.07	D axis current loop proportional gain	Range: 0~65535 <b>【10000】</b>
P4.08	D axis current loop integral gain	Range: 0~65535 <b>【2000】</b>
P4.09	Q axis current loop proportional gain	Range: 0~65535 <b>【10000】</b>
P4.10	Q axis current loop integral gain	Range: 0~65535 <b>【2000】</b>

**7.6 Multi-function terminal (P5)**

P5.00	Function of multi-function terminal X1	Range: 0~43 <b>【0】</b>
P5.01	Function of multi-function terminal X2	Range: 0~43 <b>【0】</b>
P5.02	Function of multi-function terminal X3	Range: 0~43 <b>【0】</b>
P5.03	Function of multi-function terminal X4	Range: 0~47 <b>【0】</b>
P5.04	Function of multi-function terminal X5	Range: 0~48 <b>【0】</b>
P5.05	(Reserved)	
P5.06	(Reserved)	
P5.07	(Reserved)	

## Users Manual

The multi-function terminals can realize various functions. You may assign functions to them by setting parameters P5.00~P5.04. Please refer to Table 5-3. Take X1~X3 for example in the following description.

Table 5-2 Functions of multi-function terminals

Setting	Functions	Setting	Functions
0	No function	1	MS frequency 1
2	MS frequency 2	3	MS frequency 3
4	Acc/Dec time 1	5	Acc/Dec time 2
6	External fault normally-open input	7	External fault normally-closed input
8	Reset signal	9	Forward jog
10	Reverse jog	11	Coast-to-stop input
12	Frequency increase(UP)	13	Frequency decrease(DN)
14	PLC operation pause	15	Acc/Dec prohibit
16	3-wire operation control	17	External interrupt signal normally-open input
18	External interrupt signal normally-close input	19	DC injection braking command
20	Disable close-loop	21	Disable PLC
22	Frequency setting method 1	23	Frequency setting method 2
24	Frequency setting method 3	25	Reference freq. is input via CCI
26	Reserved	27	Terminal control mode is forcibly enabled
28	Control mode 1	29	Control mode 2
30	MS close-loop 1	31	MS close-loop 2
32	MS close-loop 3	33	Start traverse operation
34	Reset the traverse operation status	35	External stop command
36	Reserved	37	Inverter operation prohibiting
38	Reserved	39	Clear length
40	Clear auxiliary reference frequency	41	Reset PLC stop status
42	Clear counter's record	43	Signal of triggering counter
44	Input the signal of length	45	Pulse input
46	Single phase speed measuring	47	Speed measuring input SM1 (only for X4)
48	Speed measuring input SM2 (only for X5)		

The functions are explained as follows:

### 1~3: MS terminals

If any three of P5.00~P5.02 are set at 1, 2, 3 respectively, Up to 8 segments of speed can be defined through the combination of the ON and OFF state of the 3 terminals.

Table 5-3 MS Speed

X <sub>3</sub>	X <sub>2</sub>	X <sub>1</sub>	Freq.
OFF	OFF	OFF	Common freq.
OFF	OFF	ON	MS freq. 1
OFF	ON	OFF	MS freq. 2
OFF	ON	ON	MS freq.3
ON	OFF	OFF	MS freq.4
ON	OFF	ON	MS freq. 5
ON	ON	OFF	MS freq. 6
ON	ON	ON	MS freq. 7

The MS frequency will be used in MS running and simple PLC operation. e.g.: Set the parameters corresponding to X1, X2 and X3: P5.00=1, P5.01=2, P5.02=3, then X1, X2 and X3 are used to perform MS running. See Figure 5-18.

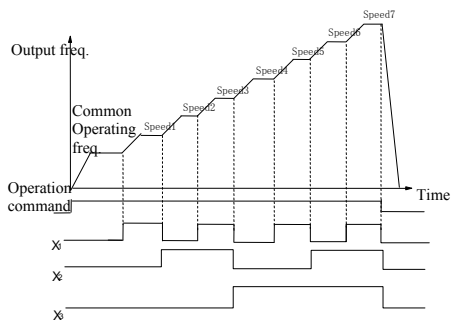

Figure 5-18 MS Running

Figure 5-19 illustrated the wiring of terminal control of MS running. K4 and K5 control the running direction. The combination of K1, K2 and K3 can enable common running or MS running with 1~7 speeds.

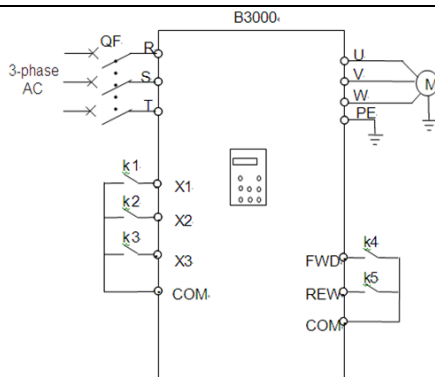

Figure 5-19 Wiring of MS running

#### 4~5: Acc/Dec time terminal

Table 5-4 Acc/Dec Time Selection

X2	X1	Acc/Dec time selection
OFF	OFF	Acc time 1/ Dec time 1
OFF	ON	Acc time 2/ Dec time 2
ON	OFF	Acc time 3/ Dec time 3
ON	ON	Acc time 4/ Dec time 4

By combination of the ON/OFF state of Terminal 1 and 2, you can get 4 groups of Acc/Dec time.

#### 6~7: External fault signal (normally-open/close input)

If the setting is 6~7, fault signal of external equipment can be input via the terminal, which is convenient for the inverter to monitor the fault of external equipment. Once the inverter receives the fault signal, it will display “F.ED”. The fault signal has two input modes, i.e. normally-open and normally-close.

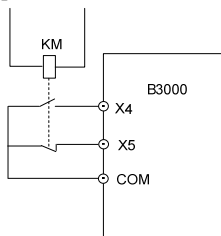

Figure 5-20 Normally-open/close input

In Figure 5-20, X4 is normally open input and X5 normally close input. KM is external fault relay.

#### 8: Reset

If any of P5.00~P5.04 is set at 8, the inverter can be reset via the terminal when the inverter has a fault. The function of this terminal is the same with the RESET key on the keypad.

**9~10: External jog command (JOGF/JOGR)**

If any of P5.00~P5.04 is set at 9~10, the terminal can enable the jog operation. JOGF is terminal for forward jog operation command and JOGR is terminal for reverse jog operation command. Jog frequency, jog interval and jog Acc/Dec time are defined in P9.05~P9.08.

**11: Coast to stop**

This function is the same with P2.08, however, it is realized by terminal and convenient for remote control.

**12~13: Frequency increase (UP) /decrease (DN)**

If the setting is 12~13, the terminal can be used to increase or decrease frequency instead of ▲ and ▼ keys on the panel for remote control. This terminal is valid when P0.00=1 or P0.03=2. Increasing or decreasing rate is determined by P5.09.

**14: Pause command for simple PLC:**

If the setting is 14, the terminal is used to pause the PLC operation and the inverter operates at zero frequency when the terminal is enabled, but the running time is not counted. If the terminal is disabled, the inverter will start at start frequency and continue the PLC operation. Refer to PD.00~PD.14 for the use of this terminal.

**15: Acc/Dec prohibit**

The motor is immune to any external command except Stop command and maintain the present speed.

---

**Note :**

This function is disabled during normal decelerating to stop.

**16: 3-wire operation control**

Refer to P5.08.

**17~18: External interrupt signal normally-open input**

When the inverter receives an interrupt signal during running, it will stop outputs and run at zero frequency. Once the signal removed, the inverter will resume previous running at start frequency.

As Figure 5-20 shows, there are X4, normally open contacts and X5, normally closed contact.

---

**Note:**

Different from function 6~7, the external interrupt signal will not cause alarm, and the inverter will resume previous running once the signal removed.

---

**19: DC Braking (DB)**

If the setting is 19, the terminal can be used to perform DC injection braking to the motor that is running for emergency stop and accurate location. Initial braking frequency, braking delay time and braking current are defined by P2.09~P2.11. Braking time is decided by the bigger value between P2.12 and the period that the terminal is effective.

**20: Disable close-loop**

If the setting is 20, the terminal can be used to realize the flexible switching between close-loop operation and low level operating mode.

When the inverter is switched to low level operating mode, its start/stop, operating direction, ACC/Dec time are shifted to the corresponding operating modes accordingly.

**21: Disable PLC**

If the setting is 21, the terminal is used to realize the flexible switching between PLC operation and low level operating mode.

When the inverter is switched to low level operating mode, its start/stop, operating direction, ACC/Dec time are shifted to the corresponding operating modes accordingly.

**22~24: Reference frequency setting method**

Through the combination of the ON/OFF state of X1, X2 and X3, you can select different frequency setting method, which will come into effect regardless of P0.02.

Table 5-5 Frequency Setting Mode Selection

X3	X2	X1	Mode
OFF	OFF	OFF	None
OFF	OFF	ON	Digital setting 1
OFF	ON	OFF	Digital setting 2
OFF	ON	ON	Digital setting 3
ON	OFF	OFF	VCI analog setting
ON	OFF	ON	CCI analog setting
ON	ON	OFF	Pulse
ON	ON	ON	LED keypad

**25: Frequency reference is input via terminal CCI**

If the setting is 25, the frequency reference will be input via terminal CCI forcibly. The frequency input will be changed to the previous one if this terminal function is disabled.

**26: Reserved****27: Terminal control mode is enabled**

When this terminal function is enabled, the operating command is input through this terminal forcibly. The inverter will be controlled in the previous mode if FWD/REV terminal function is disabled.

**28~29: Control mode selection X1~X2**

Table 5-6 Control Mode Selection

X2	X1	Control mode
OFF	OFF	None
OFF	ON	LED keypad
ON	OFF	Terminal
ON	ON	Serial port

The selection of control mode is realized by the combination of ON/OFF state of any two of X1~X5. In the above table, you should set P5.00=28, P5.01=29.

### **30~32: MS close-loop terminal (3 terminals of X1~X5)**

Table 5-7 MS Close-loop Setting Selection

X3	X2	X1	MS close-loop reference
OFF	OFF	OFF	By P5.01
OFF	OFF	ON	MS close-loop setting 1
OFF	ON	OFF	MS close-loop setting 2
OFF	ON	ON	MS close-loop setting 3
ON	OFF	OFF	MS close-loop setting 4
ON	OFF	ON	MS close-loop setting 5
ON	ON	OFF	MS close-loop setting 6
ON	ON	ON	MS close-loop setting 7

The various MS close-loop setting is realized by the combination of ON/OFF state of terminal X1~X3. In the above table, you should set P5.00=30, P5.01=31, P5.02=32

### **33: Start traverse operation**

If the traverse operation is set to be manual start, then traverse function is enabled if this function is selected. Refer to F6.

### **34: Traverse reset**

If traverse operation is enabled, closing the terminal can clear the information about traverse status no matter the inverter is in auto or manual start mode. Traverse operation continues after this terminal is disconnected. See PC.

### **35: External Stop command**

This Stop command is valid to all control modes. When this function is enabled, the inverter will stop as specified P2.08.

### **36: Reserved**

### **37: Prohibit inverter from operating**

If this function is enabled, the inverter that is operating will coast to stop and the inverter ready to run will be prohibited to start. This function is mainly used as safety protection.

### **38: Reserved**

### **39: Clear the length information**

The setting of PC.09 (length) will be cleared to zero.

### **40: Clear the setting of auxiliary reference frequency**

This function is valid for auxiliary reference frequency (P0.03=1, 2 and 3) to clear it to zero, so that the reference frequency is determined solely by main reference.

### **41: Reset PLC state**

When the inverter stops in PLC mode, the memorized PLC operating information (operating stage, operating time, operating frequency, etc.) will be cleared.

**42: Clear the counter to zero**

This function is to clear the counter to zero and is used in conjunction with function 43.

**43: Input signal to trigger the counter**

When the setting is 43, this terminal is used to input counting pulse signal to the internal counter of the inverter. The max. pulse frequency is 200Hz. The present counting value can be saved at power off. See P6.10 and P6.11 for details.

**44: Input the signal of length**

This function is only effective to multi-function input terminals X4 and X5. The terminal is used in fixed-length control. Length is calculated by input pulses. See PC.08~PC.13 for details.

**45: Pulse frequency input**

This function is effective only to multi-function input terminals X4 and X5. The terminal is used to input pulse signal that is used as frequency reference. Refer to F1 parameters for the relationship between input pulse frequency and the reference frequency.

**46: Single-phase speed measuring input**

This function is effective only to multi-function input terminals X4 and X5. See section 3.2.3 for input characteristics. The speed control accuracy is  $\pm 0.1\%$ . Single-phase speed feedback control can be realized by using this terminal and PG.

**47: Speed measuring input SM1**

**48: Speed measuring input SM2**

This function is effective only to multi-function input terminals X4 and X5. See section 3.2.3 for input characteristics. The speed control accuracy is  $\pm 0.1\%$ . 2-phase speed feedback control can be realized by using this terminal and PG.

---

**Note:**

When the inverter is in motor auto-tuning status, No. 44~47 functions of X4 are disabled automatically.

P5.08 Terminal control mode	Range: 0~3 <b>【0】</b>
-----------------------------	-----------------------



## Users Manual

This parameter defines four operating modes controlled by external terminals.

0: 2-wire operating mode 1

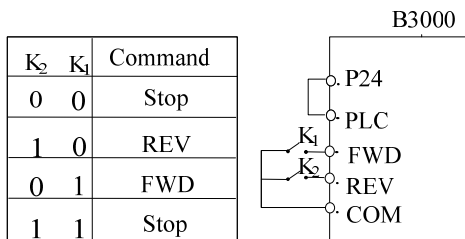

Figure 5-21 2-wire Operation Mode 1

1: 2-wire operating mode 2

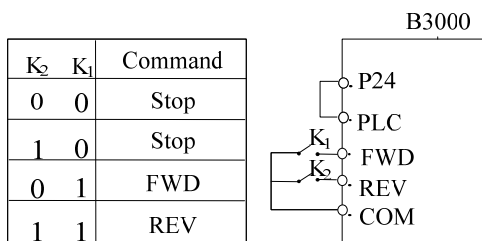

Figure 5-22 2-wire Operation Mode 2

2: 3-wire operating mode 1

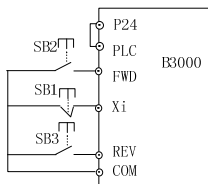

Figure 5-23 3-wire Operation Mode 1

SB1: Stop button; SB2: Run forward button; SB3: Run reverse button  
Terminal Xi is the multi-function input terminal of X1~X5. For this case, the corresponding parameter should be set at 16 (3-wire operation).

3: 3-wire operating mode 2

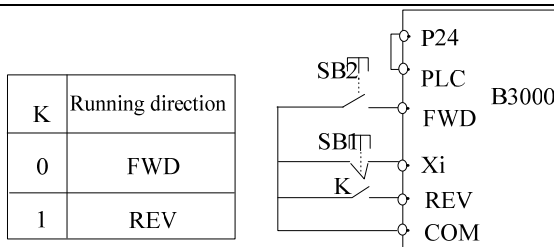

Figure 5-24 3-wire Operation Mode 2

SB1: Stop button; SB2: Run button

Terminal Xi is the multi-function input terminal of X1~X5. For this case, the corresponding parameter should be set at 16 (3-wire operation).

### Note:

In terminal control mode, for 2-wire operating mode 1 and 2, although the terminal is effective, the inverter will not run if there is external stop command. If you want to start the inverter, you should activate FWD/REV terminal again, e.g. set any of P5.00~P5.04 at 11 or 35, PLC stop after single cycle, stop after preset length arrival, Stop key pressed (see P9.21). When the inverter stops due to a fault, it will start immediately if the terminal FWD/REV is enabled and the fault is cleared.

P5.09	UP/DN rate	Range: 0.01~99.99Hz/s 【1.00Hz/s】
-------	------------	----------------------------------

To define the increase/decrease rate when using UP/DN terminal to change reference frequency.

P5.10	Freq. Curve selection	Range: 000~111 【000】
P5.11	Gain of reference frequency selector	Range: 0.00~9.99 【1.00】
P5.12	Filter constant	Range: 0.01~50.00s 【0.50s】
P5.13	Max. input pulse freq.	Range: 0.1~50.0kHz 【10.0kHz】
P5.14	Ratio of Min. input of curve 1	Range: 0.0%~P5.16 【2.0%】
P5.15	Frequency corresponds to min. input if curve	Range: 0.0~P0.09 【0.00Hz】
P5.16	Ratio of Max. input of curve1	Range: P5.14~100.0% 【100.0%】
P5.17	Frequency corresponds to max. input of curve 1	Range: 0.0~P0.09 【50.00Hz】
P5.18	Ratio of Min. input of curve2	Range: 0.0%~P5.20 【0.0%】
P5.19	Frequency corresponds to min.	Range: 0.0~P0.09 【0.00Hz】

## Users Manual

input	
P5.20 Ratio of Max. input of curve 2	Range: P5.18~100.0% 【100.0%】
P5.21 Frequency corresponds to max. input	Range: 0.0~P0.09 【50.00Hz】

When selecting VCI and CCI or PULSE input as open loop setting method, the process is shown in Figure 5-25.

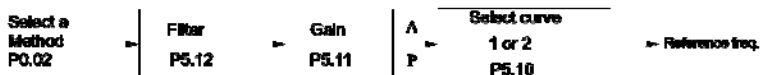

Figure 5-25 The process of setting reference freq.

After the input passes through the filter and gain processor, the relationship of its value and reference frequency is determined by curve 1 or curve 2, which are decided by P5.14~P5.17 and P5.18~P5.21 respectively. Both of them can work as positive or negative logic, as shown in Figure 5-26.

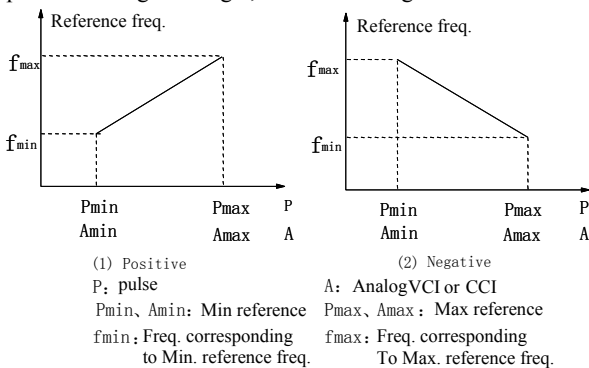

Figure 5-26 Reference freq. curve

When the analog input A is 100%, it is a 10V or 20mA signal and the reference frequency is the maximum; when the pulse input is 100%, it corresponds to P5.13 (max. input pulse frequency).

P5.12 defines the filter time. The longer the time, the stronger the immunity to disturbance, the slower the response, and vice versa.

P5.10 is to select the reference frequency curve of VCI, CCI and PULSE setting method, see Figure 5-27.

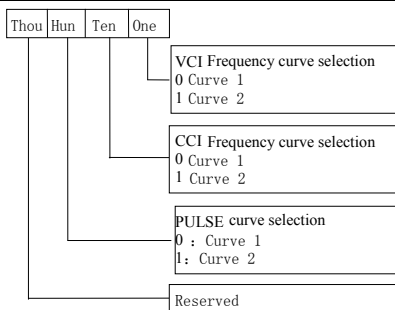

Figure 5-27 Frequency curve selection

Suppose you want to:

- ① set reference frequency by terminal pulse signal;
- ③ input signal range: 1kHz~20kHz;
- ④ 1kHz input for reference frequency 50Hz, 20kHz input for reference frequency 5Hz;

To meet the above requirement, you should set:

- ① P0.02=5, set terminal pulse mode;
- ② P5.03=45, input pulse signal from X4;
- ③ P5.10=100, select curve 2;
- ④ P5.13=20.0 kHz, set max. pulse frequency at 20kHz;
- ⑤  $P5.18=1 \div 20 \times 100\%=5.0\%$ , to set the ratio of min input of curve 2 (1kHz) to F1.03 (20kHz) ;
- ⑥ P5.19=50.00Hz; reference frequency corresponds to min. input.
- ⑦  $P5.20=20 \div 20 \times 100\%=100.0\%$ , to set the ratio of max. input of curve 2 (1kHz) to P1.04 (20kHz);
- ⑧ P5.21=5.00Hz, to set the reference frequency corresponding to max. input.

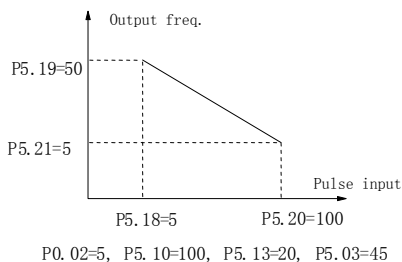

Figure 5-28 Frequency Set By Pulse Signal

## 7.7 Output terminal control parameters (P6)

P6.00	Open collector output terminal Y1	Range: 0~19 <b>【0】</b>
P6.01	Open collector output terminal Y2	Range: 0~32 <b>【1】</b>
P6.02	Relay 1 output function	Range: 0~19 <b>【16】</b>
P6.03	Relay 2 output function	Range: 0~19 <b>【16】</b>

Refer to section 3.3.2 for the output characteristics of Y1, Y2 and the relay's output terminal. Table 5-8 shows the functions of the above 3 terminals. Note that one function can be selected repeatedly.

F6.01=20~32, Y2 is the output pulse frequency, range: 0~max. pulse frequency (P6.10). The relation between the output pulse frequency and the parameters it presents are shown in 20~32 in the table below. The extended function 2 of host is to control Y2 by serial port directly. The max setting of P6.10 is 65535.

Table 5-8 Parameter Setting and Function of Output Terminals

Setting	Function	Setting	Function
0	Inverter running signal (RUN)	1	Frequency arrival signal (FAR)
2	Frequency detection threshold (FDT1)	3	Frequency detection threshold (FDT2)
4	Overload signal (OL)	5	Low voltage lock-up signal (LU)
6	External stop command (EXT)	7	Higher limit of frequency (FHL)
8	Lower limit of frequency (FLL)	9	Zero-speed running
10	Completion of simple PLC operation	11	PLC cycle completion indication
12	Preset counting value arrival	13	Specified counting value arrival
14	Preset length arrival	15	Inverter is ready (RDY)
16	Inverter fails	17	Extended function 1 of host
18	Upper and lower limits of traverse frequency	19	Preset operation time out

Setting	Function	Range
20	Freq. before slip compensation	0~Max. output freq.

Setting	Function	Range
21	Freq. after slip compensation	0~Max. output freq.
22	Preset freq.	0~Max. output freq.
23	Output current	0~2 times of inverter's rated current
24	Output current	0~2 times of inverter's rated current
25	Output torque	0~2 times of inverter's rated torque
26	Output voltage	0~1.2 times of inverter's rated voltage
27	Bus voltage	0~800V
28	VCI	0~10V
29	CCI	0~10V/0~20mA
30	Output power	0~2 of rated power
31	Extended function 2 of host	0~65535
32	Potentiometer setting(for power lower thanB3000-4T0040G)	0~10V

The explanation of output signal is shown in Table 5-8.

0: Inverter running signal (RUN)

This signal will be given if the inverter is running.

1: Frequency arrival signal (FAR)

See P6.13.

2: Frequency detection threshold (FDT1)

See P6.14~P6.15.

3: Frequency detection threshold (FDT2)

See P6.16~P6.17.

4: Overload signal (OL)

The signal will be given if the inverter's output current is bigger than the value defined by FL.05 and the overload time is longer than the time defined by FL.06. This function is usually used for overload pre-alarm. See Figure5-78.

5: Low voltage lock-up signal (LU)

The signal will be given when the DC bus voltage is lower than the low voltage limit, and the LED displays "-LU-".

6: External stopping command (EXT)

The terminal outputs the indicating signal if the inverter outputs tripping signal caused by external fault (F.Ed).

7: Higher limit of frequency (FHL)

The signal is given if the preset frequency is higher than upper limit of frequency and the operating frequency reaches the upper limit of frequency.

8: Lower limit of frequency (FLL)

The signal is given if the preset frequency is higher than lower limit of frequency and the operating frequency reaches the lower limit of frequency.

9: Zero-speed running

The signal is given if the inverter's output frequency is 0 and the inverter is in operating status.

10: Completion of simple PLC operation stages

The signal is given (pulse, 500ms) if the present stage of PLC operation is finished.

11: PLC cycle completion indication

The signal (pulse, 500ms) is given if one cycle of PLC operation is finished.

12: preset counting value arrival

13: reference length arrival

Refer to P6.11~P6.12.

14: preset length arrival

The signal is given if the setting of PC.09 (actual length) is bigger than PC.08 (preset length). The length counting terminal is the one whose parameter (P5.03 or P5.04) is set at 44.

15: Inverter is ready (RDY)

The RDY signal is output when the inverter has no fault, its DC bus voltage is normal; the Start Prohibit function is disabled. It is ready to start.

16: Inverter fails

The signal is given if the inverter has faults.

17: Extended function 1 of host

The output signal of terminal Y1, Y2 or TC is directly controlled by a serial port. Refer to the communication protocol of B3000.

18: Upper and lower limits of traverse frequency

The signal will be given if the range of traverse frequency calculated based on central frequency is higher than upper limit of frequency (P0.07) or lower than the lower limit of frequency (P0.08), as shown in Figure 5-29.

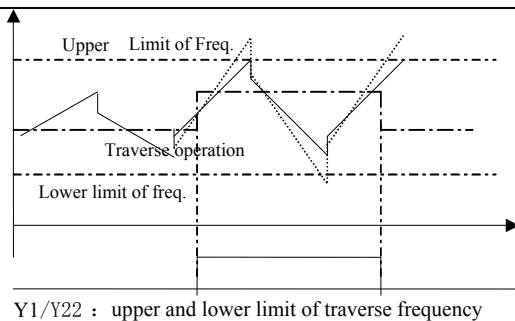

Figure 5-29 Limiting the amplitude of traverse

19: preset operating time out

The signal is given if the inverter's total operating time (PN.01) reaches preset operating time (PN.00).

P6.04	AO1 output function	Range: 0~12 <b>【0】</b>
P6.05	AO2 output function	Range: 0~12 <b>【3】</b>
P6.06	Reserved	

AO1 and AO2 are analog output terminals.

Refer to section 3.3.2 for the output characteristics of AO1 and AO2.

Refer to Table 5-9 for the function of P6.04 and P6.05.

Table 5-9 Signals from AO1 and AO2

Setting	Function	Range
0	Output freq. before compensation	0~Max. output freq.
1	Output freq. after compensation	0~Max. output freq.
2	Preset freq.	0~Max. output freq.
3	Output current	0~2 times of inverter's rated current
4	Output current	0~2 times of motor's rated current
5	Output torque	0~2 times of motor's torque
6	Output voltage	0~1.2 times of inverter's rated voltage
7	Bus voltage	0~800V
8	VCI	0~10V
9	CCI	0~10V/0~20mA
10	Output power	0~2 times of rated power
11	Extended function 2 of host	0~65535
12	Setting of potentiometer	0~10V



## Users Manual

Using extended function 2 of host, AO1 and AO2 output can be controlled by serial port directly, the output of AO1 or AO2 “65535” corresponds to max. analog output 10V (20mA) .

Suppose you want:

AO1 outputs 4~20mA, which means the bus voltage is 0~800V.

You should do the following configuration:

- ① P6.04=7, output signal presenting bus voltage;
- ② P6.07=01, AO1 output: 4~20mA;
- ③ P6.08=100%, output gain 100%;
- ④ Select 0/4-20mA of CN4 (SW2) jumper.

### Note:

When X5 is select as 44 ~ 46, Y2 pulse output will be invalid.

P6.07 Analog output range	Range: 00~11 【00】
---------------------------	-------------------

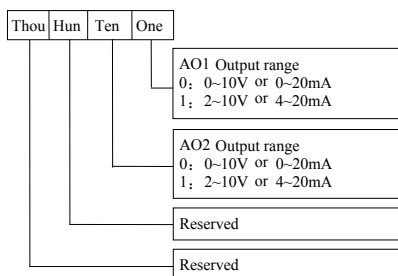

Figure 5-30 Analog Output Type Selection

The parameter is to select the output type, i.e. voltage or current, of AO1 and AO2.

CN4(SW2) jumper is for AO1, “I” represents current, “V” represents voltage.

CN5(SW3) jumper is for AO2, “I” represents current, “V” represents voltage.

P6.08 AO1 output gain	Range: 0.0~200.0% 【100.0%】
P6.09 AO2 output gain	Range: 0.0~200.0% 【100.0%】

You can change the measurement range or calibrate error of AO1 and AO2 outputs by adjusting the output gain.

### Note:

The parameter will come into effect immediately while you change it.

P6.10 Y2 Max output pulse freq. of Y2	Range: 0.1~50.0kHz 【10.0KHz】
---------------------------------------	------------------------------

It defines the max. pulse frequency from terminal Y2. Refer to P6.11.

P6.11 Preset counting value	Range: P6.11~9999 【0】
-----------------------------	-----------------------

## Users Manual

P6.12 Specified counting value	Range: 0~P6.10 【0】
--------------------------------	--------------------

F6.11 and P6.12 are complementary to Function No.12 and No.13 in Table 5-9.

When the number of pulses defined by P6.11 is input from Xi, Yi or relay will output an indicating signal.

Suppose F6.11=8, as Figure 5-31 shows, when 8 consecutive pulses are input from Xi, Y1 will output an indicating signal.

When the number of pulses defined by P6.12 is input from Xi, Yi or relay will output an indicating signal which will last until the number of pulses defined by P6.11 is input.

Suppose P6.12=5, 6.11=8, as Figure 5-31 shows, when 5 consecutive pulses are input from Xi, Y2 will output an indicating signal and it holds the signal until the 8th pulse passes. Note that if P6.12 is bigger than P6.11, then P6.12 is invalid.

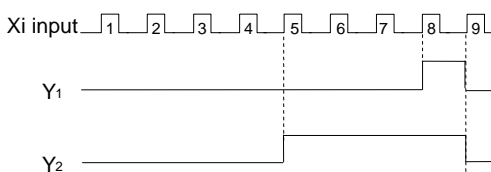

Figure 5-31 Preset counting value and specified counting value

P6.13 Freq. arrival detection range (FAR)	Range: 0.00~650.00Hz 【2.50Hz】
---	-------------------------------

As shown in Figure 5-32, if the inverter's output frequency is within the detecting range of preset frequency, a pulse signal will be output. It is complementary to No.1 function in Table 5-8.

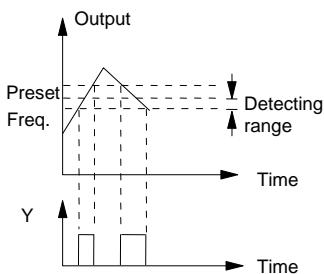

Figure 5-32 Freq. Arrival Signal Output

P6.14 FDT1 level	Range: 0.00~650.00Hz 【50.00Hz】
P6.15 FDT1 lag	Range: 0.00~650.00Hz 【1.00Hz】
P6.16 FDT2 level	Range: 0.00~650.00Hz 【25.00Hz】
P6.17 FDT2 lag	Range: 0.00~650.00Hz 【1.00Hz】

## Users Manual

P6.14~P6.15 is a complement to the No.2 function in Table 5-8. P6.16~P6.17 is a complement to the No.3 function in Table 5-8. Their functions are same. Take P6.14~P6.15 for example: when the inverter's output frequency reaches FDT1 level, it outputs an indicating signal until its output frequency drops below FDT1 level (FDT1 level-FDT1 lag). As shown in Figure 5-33.

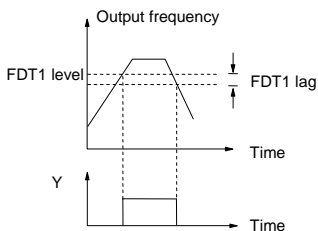

Figure 5-33 Frequency Detection

## 7.8 Close-loop control (P7)

Usually, the close loop control can be divided into two types: analog close loop and pulse close loop according to feedback. Figure 5-34 and Figure 5-35 are analog and pulse close loop control wiring diagram.

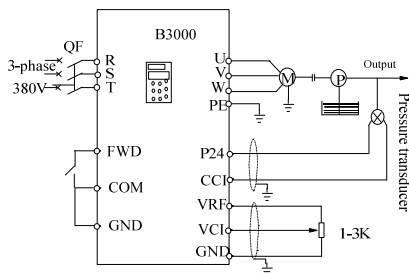

Figure 5-34 Build-in PI Analog Feedback Control

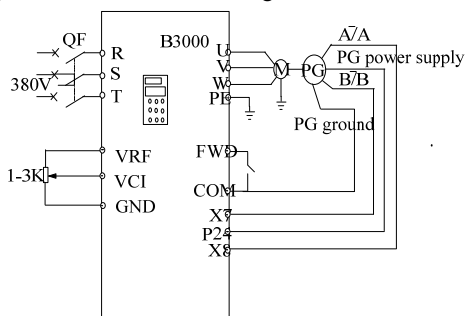

Figure 5-35 PG Speed Close Loop Control System

Analog feedback control system:

## Users Manual

---

An analog feedback control system can be formed by a pressure transducer as the feedback sensor of the internal PI.

As shown in Figure 5-34, pressure reference (voltage signal) is input via terminal VCI, while the feedback pressure value is input to terminal CCI in the form of 0~20mA current signal. The reference signal and feedback signal are detected by the analog channel. The start and stop of the inverter can be controlled by terminal FWD.

The above system can also use a TG (speed measuring generator) as speed close speed-loop control.

PG speed close-loop control:

A speed close-loop control system can be formed by external control terminals X4 and X5, and pulse generator (PG) .

As shown in Figure 5-35, close speed-loop input can come from a potentiometer in the form of voltage signal via terminal VCI, while the feedback value of the close loop is input by PG in pulse mode via terminal X4 and X5. The start and stop of the inverter can be controlled by terminal FWD.

In Figure 5-35,

A and B are PG's dual phase quadrature output;

P24 is connected to the power source of PG;

Speed reference is the voltage signal of 0~10V. The voltage signal corresponds to synchronous speed  $n_0$  which, in turn, corresponds to 0~Max frequency (P0.09). P is the number of poles of motor (FH.00) .

$$n_0 = 120 \times f_{max} / P$$

Refer to function No. 47~48 of P5.00~P5.04 for the functions of input terminals X4, X5.

---

### Note:

- 1 . The reference can also be input via keypad or serial port;
  - 2 . Dual-phase input can improve the speed measurement accuracy, while single phase input wiring is simple;
  - 3 . Dual-phase pulse can only be input in quadrature mode;
  - 4 . If PG is supplied from terminal P24, then the max load current of optical PG must be less than 100mA.
- 

The mechanism of the build-in PI is shown in the figure below:

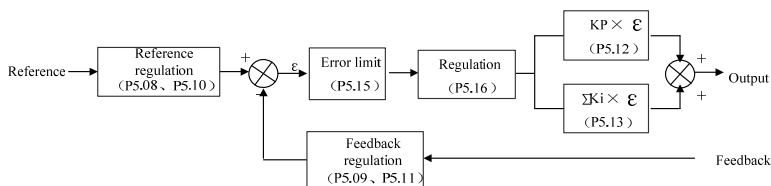

Figure 5-36 PI Working Mechanism

In Figure 5-36, KP: proportional gain. KI: integral, refer to P7.01~P7.15 for the definitions of close-loop reference, feedback, error limit and proportional and Integral parameters.

There are two features of internal PI:

The relationship between reference and feedback can be defined by P7.08~P7.11.

For example: In Figure 5-34, if the reference is 0~10V analog signal, the expected controlled value is 0~1MP, and the pressure signal is 4~20mA, then the relationship between reference and feedback is shown in Figure 5-37.

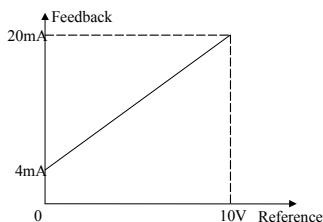

Figure 5-37 Reference (Input) and Feedback

The reference value is based on 10V (i.e. 10V means 100% input); and the feedback value is based on 20mA (20mA corresponds to 100% output).

Close-loop characteristic is selected through P7.16 to satisfy different applications.

In order to meet the control requirements, the motor's speed should be increased with reference speed. This kind of control characteristic is called positive response. If the motor speed is required to be decreased when the reference value is increased, this control characteristic is called negative response.

See Figure 5-38. P7.16 defines the two characteristics.

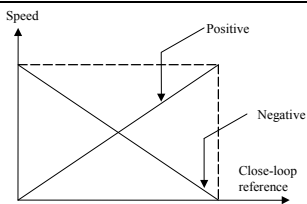

Figure 5-38 Close-loop control Characteristics

After the system type is determined, the following procedures can be used to determine the close loop parameters:

- ① Determine the close-loop reference and feedback channel (P7.01 and P7.02);
- ② Define the relationship between close-loop reference and feedback value (P7.08~P7.11);
- ③ Determine the speed reference of speed close-loop control and the number of revolutions of PG (P7.06~P7.07);
- ④ Determine the close-loop regulation characteristic, that is, if the motor speed decreases while the input reference increases, then the close-loop control characteristic should be set to negative (P5.16=1);
- ⑤ Set integral regulation and close-loop frequency (P7.17~P7.19);
- ⑥ Adjust close-loop filter time, sampling cycle, bias limit and gain factor (P7.12~P7.15).

P7.00 Close-loop control	Range: 0、1 【0】
--------------------------	----------------

0: Disabled

1: Enabled

P7.01 reference input method	Range: 0~2 【1】
------------------------------	----------------

0: digital setting

Take the value of P7.05 (set analog close-loop feedback, P7.02=0~5);

Take the value of P7.06 (set pulse close-loop feedback, P7.02=6).

1: VCI (0~10V)

2: CCI

Pay attention to the setting of jumper CN7 (SW1).

3: LED keypad (for power lower than B3000-4T0040G)

4: PULSE (for power lower than B3000-4T0040G)

### Note:

The motor speed is controlled by pulse feedback. Given analog input 10V (20mA) or max. input frequency P1.04, the output pulse will be max.

## Users Manual

frequency P0.09, which corresponds to the motor synchronous speed  $n_0$  ( $n_0 = 120f_{max}/P$ ).

P7.02 Feedback method	Range: 0~6 <b>【1】</b>
-----------------------	-----------------------

0: VCI analog voltage 0~10V

1: CCI analog input

2: VCI+CCI

3: VCI-CCI

4: Min{VCI, CCI}

5: Max{VCI, CCI}

When current input is selected, the signal will be converted to voltage signal, whose value is determined by the formula:  $V_{out} = mA/2$ ;

P7.02=6: Pulse

It can be single-phase or 2-phase PG close loop feedback. Please refer to multi-function input terminal X4, X5 (P7.03~P7.04).

P7.03 Input filter	Range: 0.01~50.00s <b>【0.50s】</b>
P7.04 Feedback filter	Range: 0.01~50.00s <b>【0.50s】</b>

Both the input signal and feedback signal have some noise signals. These signals can be filtered by setting the time constant of filter (settings of P7.03 and P7.04). The bigger the time constant, the better the immunity capability, but the response becomes slow. The smaller the time constant, the faster the response, but the immunity capability becomes weak.

P7.05 Digital reference input	Range: 0.00~10.00V <b>【0.00】</b>
-------------------------------	----------------------------------

When analog feedback is selected (P7.02=0~5), this function allows parameter setting from keypad or serial port.

P7.06 Speed close-loop setting	Range: 0~39000rpm <b>【0 rpm】</b>
--------------------------------	----------------------------------

When PG pulse feedback is selected (F5.02=6), speed can be set through keypad or serial port.

P7.07 Pulse number per revolution of encoder	Range: 1~9999 <b>【1024】</b>
--	-----------------------------

Please set this parameter according to the characteristics of the pulse encoder.

P7.08 Min. input	Range: 0.0%~P7.10 <b>【0.0%】</b>
P7.09 Feedback of min. input	Range: 0.0~100.0% <b>【20.0%】</b>
P7.10 Max. input	Range: P7.08~100.0% <b>【100.0%】</b>
P7.11 Feedback of max. input	Range: 0.0~100.0% <b>【100.0%】</b>

## Users Manual

P7.08~P7.11 define the relation of analog close loop input and feedback. The values of the above parameters are percentage of input or feedback value to reference value (10V or 20mA or P5.13).

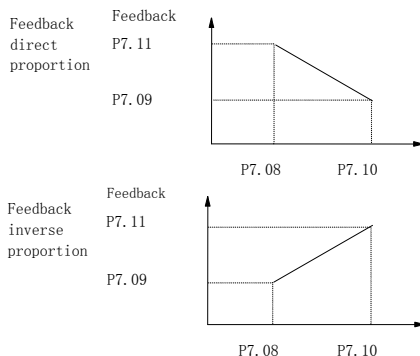

Figure 5-39 Relation of Input and Feedback

P7.12	Proportional gain	Range: 0.000~9.999 【2.000/0.050】
P7.13	Integral gain	Range: 0.000~9.999 【0.100/0.050】
P7.14	Sampling cycle	Range: 0.01~50.00s 【0.10s/0.50s】

The bigger the proportional gain, the faster the response, but oscillation may occur easily if proportional gain is too big.

If only proportional gain is used in regulation, the error cannot be eliminated completely. Therefore, it is preferred to use the integral gain to form a PI control system. The bigger the integral gain, the faster the response, but oscillation may occur if integral gain is too big.

P7.14 refers to the sampling cycle of feedback value. The PI regulator calculate once in each sampling cycle. The bigger the sampling cycle the slower the response.

P7.15	Error limit	Range: 0.0~20% 【2.0%】
-------	-------------	-----------------------

P7.15 is the max. error between system output and the close-loop reference, as shown in Figure 5-40. PI regulator stops operation when the feedback error is within this range. Setting this parameter correctly is helpful to improve the system output accuracy and stability.



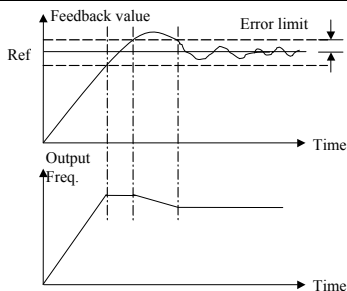

Figure 5-40 Error Limit Schematic Diagram

P7.16 Close-loop regulation characteristics	Range: 0、1 【0】
---	----------------

0: Positive logic

Set P7.16 to 0 if the motor speed is required to increase with the reference.

1: Negative logic

Set P7.16 to 1 if the motor speed is required to decrease with the increase of the reference.

P7.17 Integral regulation	Range: 0、1 【0】
---------------------------	----------------

0: Stop integral regulation when the frequency reaches the upper or lower limits

1: Continue the integral regulation when the frequency reaches the upper or lower limits

It is recommended to set the parameter at 0 for the system that requires fast response.

P7.18 Preset frequency	Range: 0.00~650.00Hz 【0.00Hz】
P7.19 Preset frequency hold time	Range: 0.0~3600s 【0.00s】

The above parameters are helpful for the close loop control to enter stable state quickly.

After close-loop running is started, the inverter will accelerate to the preset frequency P7.18 within the accelerate time, and hold the frequency for a period of time (P7.19), and then run according to close-loop characteristic.

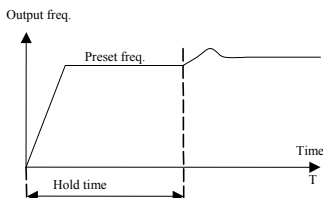

Figure 5-41 Close-loop preset frequency

**Note:**

If you don't need preset frequency, just set P7.18 and P7.19 at 0.

**7.9 MS parameters (P8)**

P8.00	MS freq. 1	Range: lower limit~upper limit 【 5.00Hz】
P8.01	MS freq. 2	Range: lower limit~upper limit 【10.00Hz】
P8.02	MS freq. 3	Range: lower limit~upper limit 【20.00Hz】
P8.03	MS freq. 4	Range: lower limit~upper limit 【30.00Hz】
P8.04	MS freq. 5	Range: lower limit~upper limit 【40.00Hz】
P8.05	MS freq. 6	Range: lower limit~upper limit 【45.00Hz】
P8.06	MS freq. 7	Range: lower limit~upper limit 【50.00Hz】

These frequencies will be used in simple PLC operation and multi-speed operation, refer to the introductions of P5.00~P5.04 and group PD parameters.

P8.07	MS close-loop setting 1	Range: 0.0~10.00V 【0.00V】
P8.08	MS close-loop setting2	Range: 0.0~10.00V 【0.00V】
P8.09	MS close-loop setting 3	Range: 0.0~10.00V 【0.00V】
P8.10	MS close-loop setting 4	Range: 0.0~10.00V 【0.00V】
P8.11	MS close-loop setting 5	Range: 0.0~10.00V 【0.00V】
P8.12	MS close-loop setting 6	Range: 0.0~10.00V 【0.00V】
P8.13	MS close-loop setting 7	Range: 0.0~10.00V 【0.00V】

Besides the 3 close-loop setting methods, the MS close-loop voltage setting F5.20~F5.26 can also be used.

MS close-loop setting 1~7 can be selected through external terminals, please refer to P5.00~P5.04 (function No. 30~32). It can also used with simple PLC close-loop, see PD parameters.

The MS close-loop setting has priority over the methods defined in P7.01.

P8.14	Acc time 2	Range: 0.1~3600s (min) 【6.0s/20.0s】
P8.15	Dec time 2	Range: 0.1~3600s (min) 【6.0s/20.0s】
P8.16	Acc time 3	Range: 0.1~3600s (min) 【6.0s/20.0s】
P8.17	Dec time 3	Range: 0.1~3600s (min) 【6.0s/20.0s】
P8.18	Acc time 4	Range: 0.1~3600s (min) 【6.0s/20.0s】
P8.19	Dec time 4	Range: 0.1~3600s (min) 【6.0s/20.0s】

Three kinds of Acc/Dec time can be defined, and the inverter's Acc/Dec time 1~4 can be selected by different combinations of control terminals, refer to P5.00~P7.07 for the definitions of terminals used to select Acc/Dec time.

**Note:**

Acc time 1 and Dec time 1 is defined in P0.12 and P0.13 respectively.

## 7.10 Enhanced function (P9)

P9.00 Digital frequency control	Range: 00~11 【00】
---------------------------------	-------------------

Valid only when P0.02=0、1、2.

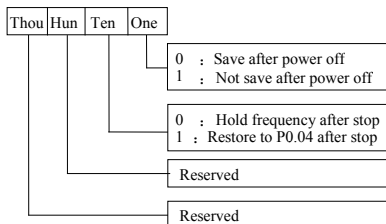

Figure 5-42 P9.00 setting

One's place of P9.00:

0: when the inverter is powered off or at undervoltage state, updates P0.04 by the actual frequency at that time.

1: when the inverter is powered off or at undervoltage state, P0.04 remains unchanged.

Ten's place of P9.00:

0: the reference frequency when the inverter stops will be saved.

1: The reference frequency will restore to P0.04 when the inverter stops.

P9.01 FWD/REV transition time	Range: 0~3600s 【0.0s】
-------------------------------	-----------------------

It refers to the time period when the inverter's rotation changes from FWD to REV or REV to FWD, see Figure 5-43 as  $t_1$ .

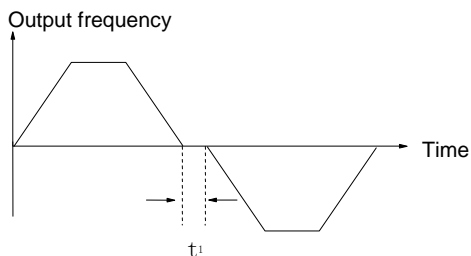

Figure 5-43 Transition time from FWD to REV

P9.02 Carrier wave frequency	Range: 0.7~15.0kHz 【depending on model】
------------------------------	---

Table 5-10 Relation of Model and Carrier Freq

Model \ CWF	Max CWF (kHz)	Min CWF (kHz)	Default (kHz)
G model: 0.75kW~4.0kW	15	0.7	8
G model: 5.5kW~15kW P model: 7.5kW~18.5kW	15	0.7	8
G model: 18.5kW~45kW P model: 22kW~55kW	10	0.7	4
G model: 55kW~75kW P model: 75kW~90kW	6	0.7	3
G model: 90kW and above P model: 110kW and above	3	0.7	2

Table 5-11 Carrier Freq. and Performance

Carrier wave Freq.	Decreasing	Increasing
Motor noise	↑	↓
Leakage current	↓	↑
Interference	↓	↑

**Note:**

- 1 .To get the best control effect, the ratio of carrier wave frequency to the max. operating frequency of the inverter should be lower than 36.
- 2 . The displayed current might have error when the carrier frequency is lower.

P9.03 CWF auto adjustment	Range: 0、1 <b>【1】</b>
---------------------------	-----------------------

0: Disabled

1: Enabled

When CWF auto adjustment is enabled, the inverter can adjust CWF automatically according to the temperature inside the inverter.

P9.04 Motor tone	Range: 0~10 <b>【0】</b>
------------------	------------------------